



# land application

*Land application of manure is such an important part of livestock operation that it ranks second only to uncontrolled discharges in potential environmental impact.*

When manure is removed from storage it is spread on hundreds of times the area it previously occupied during storage. For example, manure from a 1,000-head, 40- x 200-foot finishing pit (0.2 acres) normally will be spread on more than 140 acres—700 times as much area as it occupies in the pit.

*Improper land application* can spoil the environment and cost—both the producer and society—financially.

*Proper land application* can enhance the environment and save money. This is achieved by applying the manure at the correct rate while considering the manure, the soil, the topography, the weather, the neighbors, nearby water sources, and other pertinent factors.

## ENVIRONMENTAL SAFETY

The fundamental environmental rule that applies to all confinement feeding operations in Iowa is “confinement operations must retain all manure produced in the confinement enclosures between periods of manure application. In no case shall manure from a confinement feeding operation be discharged directly into the water of the state.”

### Manure application guidelines

The IDNR rules recommend the following manure application practices for all livestock operations, including confinement operations and open feedlots:

- To minimize the potential for leaching to groundwater, or runoff to surface waters, nitrogen application from all sources, including manure, legumes, and commercial fertilizers, must not exceed the nitrogen use levels necessary to obtain optimum crop yields for the crop being grown.
- To minimize phosphorous movement to

surface waters, manure should be applied at rates not exceeding crop uptake of phosphorus when soil tests indicate adequate phosphorous levels. Phosphorous application may be greater than crop removal for maximum crop production when soil tests indicate very low or low phosphorous levels.

- Manure application on frozen or snow-covered crop land should be avoided whenever possible. If manure is spread on frozen or snow-covered crop land, application should be limited to areas on which
  - land slopes are 4 percent or less and
  - adequate erosion control practices exist.
- Manure applied on crop land subject to flooding more than once every 10 years should be incorporated into the soil after application.
- Unless adequate erosion controls are used and unless manure is injected or incorporated, manure should not be applied within 200 feet of land draining into a stream or surface intake for a tile line or other buried conduit. Manure should not be applied on waterways.
- Injection or soil incorporation of manure is recommended where consistent with established soil erosion control practices.

## LIQUID MANURE APPLICATION SYSTEMS

### Injection systems

Manure injection systems are designed to place the manure under the soil and cover it. This method of applying manure has a number of benefits, including

- Reduced nitrogen volatilization losses;
- Reduced threat of runoff losses of nutrients and microbes;

# land application

- Reduced tillage trips due to the tillage benefits from the injectors; and
- Reduced odor during land application.

When injecting manure, application rates should be lower than broadcast rates since very little nitrogen is lost in the air.

Figure 1 (*see land application page 18*) shows ideal parameters for designing manure injection equipment.

There also are potential adverse effects of manure injection. In particular, injection can disturb the soil surface, which can significantly cover crop residue in no-till or conservation tillage systems.

Soil residue reduction varies from about 30 to 60 percent depending on the manure application system. Iowa State University data has shown corn residue remaining after injection varies from 30 to 85 percent with different injectors. A number of factors influenced performance: size and type of tool, speed, depth, tool spacing, soil type, soil condition, and the consistency and care of the operator.

The tillage tool, including various attachments, significantly affects soil surface disturbance and distribution of liquid manure in the soil. Sweeps generally cause more of an uplift of soil than chisel points, but result in better manure distribution. Figures 2 and 3 (*see land application pages 18 and 19*) show the projected areas of the tillage tools, the regions of soil disturbance, and the saturated soil for typical chisel point and sweep injectors, respectively.

The shank width (not sweep width) perhaps has the greatest influence on residue disturbance and soil roughness. This width is constrained by the necessity of allowing the flow of liquid manure without clogging. The shank often can catch residue in a hairpin fashion and hinder plowing performance. Placing a coulter in front of the shank (*see Figure 4, land application page 19*) can help by cutting through the residue and creating a path for the shank to follow. However, in some cases the residue may be so thick that even the coulter becomes clogged. Closing disks or some other device may help

keep soil in a restricted region, thereby preventing some of the residue coverage. (*See figures 5-7, land application pages 20 and 21.*)

Adjust your tractor speed to provide the best performance of the tillage implement. However, you must consider the time required to dispose of manure and the desired application rate (gallons/acre). Flow control may be necessary to achieve the desired application rate and to operate at an optimal speed for the best performance of the tillage implement. Some manure application systems have this feature. Umbilical systems which operate with a secondary power unit, such as another tractor driving the pump, allow for flow control. Other systems include attachments with orifice-type restrictions to control flow. Because more precise application rates and calibration likely will be required, future designs should include flow control features that allow you to set your desired speed and flow rate. Injector spacing also greatly affects performance. Keep in mind the following considerations:

- Less residue is destroyed as the spacing is increased.
- Wider spacing results in greater manure flow through each injector and less uniformity, but facilitates covering more ground faster.
- Planting too close to “hot spots,” or areas with high concentrations of liquid manure, can adversely affect plant growth, particularly if the manure is injected in the spring. Sweeps help avoid hot spots, but also affect residue retention.

## Broadcast systems

There are three systems used to broadcast manure:

- Liquid tank spreaders,
- Dry spreaders, and
- Irrigation systems.

Each of these systems has two major management concerns: applying the manure at the

# land application

proper rate and achieving uniform distribution. In general, application patterns for broadcast systems tend to be less uniform than for injection systems.

For liquid tank and dry spreaders, application patterns typically are high in the center (behind the spreader) and taper down toward the edges. This is especially true for dry box spreaders. To achieve a uniform application and avoid streaked crops, the edges must be overlapped. The amount of overlap will be determined by the particular machine and its specific distribution characteristics. The amount of overlap in turn affects the overall application rate, because it affects the distance between passes; this is also true of traveling gun irrigation systems. Other factors that can distort application patterns are wind, sloping ground, and partial plugging. Center pivot irrigation systems are less sensitive to these problems because they are typically designed for “whole field” coverage. Good management is required in all cases to achieve uniform application at the right rate when broadcasting manure.

## Irrigation systems

Although irrigation is not used as extensively in Iowa as some other states, its use is increasing. The potential for crop damage and environmental pollution by lagoon liquid irrigation systems requires additional knowledge and management.

Use irrigation scheduling (the management routine used to accomplish the right balance) to answer these questions:

- Do I need to irrigate?
- How much should I apply?

## DETERMINING THE PROPER RATE

*Applying manure at the correct rate is the most important element of environmentally friendly manure management.* Use your nutrient management plan to determine your manure application rate. Instructions for developing a nutrient management plan can be found in the nutrients management section. (**Note:** Developing the

plan is the responsibility of the producer.) Next, apply the gallons or tons per acre of manure to supply the nutrients called for in the plan. (**Note:** Applying the correct amount of manure according to the plan is the responsibility of the applicator.)

Manure from different types of storage systems (pits, lagoons, or dry manure) must be applied at different rates because of varying nutrient contents. (*See Table 2, nutrient management section page 7.*)

- Pit manure is relatively concentrated and is typically applied at 2,000 to 8,000 gallons/acre.
- Lagoon liquid is relatively dilute and is typically applied at 20,000 to 50,000 gallons/acre.
- Dry poultry layer manure typically is applied at 5 to 15 tons/acre.
- Dry bedded manure is applied at 10 to 25 tons/acre.

The actual rates should be determined by your manure management plan and the actual nutrient concentration of the manure.

---

### Example:

Your manure nutrient plan calls for 140 pounds N/acre from the manure you will apply. Your pit manure contains 50 pounds/1,000 gallons and will contribute 49 pounds after deducting 2 percent losses from injection ( $0.98 \times 50 = 49$ ). Your application rate should be:

$$(140/49) \times 1,000 = 2,857 \text{ gals./acre using manure from a pit}$$

If you pump through a drag hose injection system from a lagoon that contains only 4 pounds/1,000 gallons your application rate should be:

$$(140/4) \times 1,000 = 35,000 \text{ gals./acre using manure from a lagoon}$$

(27,000 gals./acre is equivalent to a 1-inch rain.)

# land application

The manure's nutrient concentration is critical to determining how much manure to apply. However, the soil's capacity for holding water, rather than the amount of nutrients, often limits the amount of lagoon liquid to be applied. In the example above, 35,000 gallons/acre is too much to apply at once. It must be applied in two or more applications.

---

**Example:**

You are applying solid manure from a high-rise layer house. Each ton contains 35 pounds N. Calculate the application rate to supply 120 pounds/acre to the land. Since the manure will be broadcast, you will retain 70 percent of the N (*see Table 4, nutrients management section page 9.*)

After deducting the application loss your manure will contain:

$$35 \times 0.7 = 24.5 \text{ lbs. N/ton}$$

You should apply:

---

$$120/24.5 = 4.9 \text{ tons/acre}$$

## SOIL-WATER RELATIONSHIPS

Before attempting to measure or estimate soil-water content, you should understand some basic soil-water relationships:

*Soil* is composed of three major parts: air, water, and solids.

*Pore volume* is that portion of soil occupied by air and water.

*Saturation* occurs when all soil pores are filled with water. Any water added to the soil under this condition will either run off or leach below the root zone. Saturated conditions are undesirable for good crop growth or any additional liquid application.

*Field capacity* is the point at which the soil has

had time to drain away excess water from the large pores by gravity, but still remains in a very moist condition.

*Wilting point* occurs when there is so little water left in the soil that plants cannot remove the water for their use.

Not all of the water added to soil is retained for plant use. Lagoon water should be applied so that it remains in the root zone for uptake by the crop. Any water not retained in the root zone can transport nutrients to surface water, groundwater, or both.

To interpret soil-water measurements and apply them to irrigation scheduling, you must be able to distinguish between two categories of soil water:

- **Gravitational water** is the water in the soil that is free to drain or move by the force of gravity. Gravitational water is computed as the volume of water in the soil between saturation and field capacity. When gravitational water is present in the root zone, the soil is too wet to be irrigated.
- **Plant-available water (PAW)** is the amount of water held in the soil that is available to plants. PAW is the difference between the water content at field capacity (referred to as the upper limit water content) and the permanent wilting point (often referred to as the lower limit water content).

Schedule applications to maintain the water content of the soil between these two extremes. If there is no PAW deficit, gravitational water likely is present, and wastewater irrigation should be delayed under normal operating conditions.

Soil texture greatly influences the portion of the soil pore volume that can be occupied by gravitational water or plant-available water; therefore, it is important to know your soil texture to determine how much water can be applied.

# land application

The amount of plant-available water that exists in the soil at any given time is commonly known as the “depth of water per unit depth of soil.” Typical units are inches of PAW per foot of soil depth. Plant-available water estimates for various soil textural classes are given in published soil survey reports. These estimates range from less than 0.2 inch of PAW per foot of soil for coarse sandy soils to nearly 2.0 inches of PAW per foot of soil for silty and clay soils.

## Estimating soil-water content

At the start of application, the water content in the soil should be lower than the field capacity (upper limit). The difference between the existing water content and the field capacity water content is the most that should be applied. The drier the soil, the more liquid that can be safely applied per application, provided this amount does not exceed the required nitrogen application rate. Determining the water content of the soil tells you if the soil is dry enough and, if so, how much liquid can be applied. Use one of the three following methods to estimate the amount of water present in the soil:

- 1. Feel method.** Squeeze a ball of soil in your hand and consult a chart for the particular soil about how much moisture is contained in the soil and therefore how much, if any, application can take place. (*See Table 1, land application page 22.*)
- 2. Soil moisture measurement devices.** This method uses one or more instruments to directly measure soil moisture. While an in-depth discussion of the various types of instruments is beyond the scope of this chapter, you should be aware that they exist and are appropriate for certain soil types and application situations. Consult Extension Ag Engineers and publications on irrigation for more information.
- 3. Checkbook method for irrigation.** This is an accounting approach for estimating how much soil water remains in the effective root zone. Wastewater irrigation is scheduled when the soil-water content in the root zone drops below a threshold level.

Some of the simpler checkbook methods track rainfall, evapotranspiration, and irrigation amounts. More sophisticated methods require periodic measurements of the soil-water status and moisture use rates of the crop. Checkbook methods require daily record keeping; this can, however, be programmed on a computer. Software has been developed to handle the accounting in a timely manner and recommend precise irrigation schedules. The checkbook method requires that you begin the soil-water computations when the soil is at a known water content (This is similar to knowing the beginning balance of your checking account before you start making deposits and withdrawals.) The method also requires a local, up-to-the-minute source of data on evapotranspiration.

You should select the method that is appropriate for the soils and crops, and with which you are most comfortable.

## Scheduling irrigation

Irrigation should be scheduled and managed so that

- No surface runoff occurs during irrigation;
- The root zone is not completely saturated at the end of the irrigation cycle; and
- The irrigated water does not leach below the root zone.

The amount that can or should be applied during any single irrigation cycle is controlled by how much water the soil can absorb. This varies from day to day and is influenced by

- Rainfall (when and how much it last rained, the forecast—don’t try to beat the rain);
- Crop maturity (water uptake rate of the crop);
- Soil type (texture, structure, depth, and cover);

# land application

- Effective root zone depth; and
- Evapotranspiration, which in turn is influenced by temperature, wind, and relative humidity.

Irrigation should replace the water that has evaporated from the soil or been removed by plants. This is the plant-available water deficit. Most water taken up by plants is removed in the upper half of the root zone. For the purpose of scheduling irrigation, this zone is referred to as the effective root zone depth. Soil conditions in Iowa vary widely. The rooting depths of crops in some of the clay pan soils may be only eight inches, so the effective root zone depth is about half that, or four inches. In deep soils the rooting depth may be in up to five feet. Estimate or measure the plant-available water deficit to be replaced by irrigation within this range. If the irrigation volume applied exceeds the PAW deficit, the excess either runs off or leaches below the root zone and could contaminate groundwater.

Nutrient tests and a manure nutrient plan will help determine whether nutrients or liquid volume will be the most limiting. Generally, you should not apply more than about an inch of wastewater during any single irrigation cycle. Even this amount may be too high and is not recommended for some soils.

The soil intake rate is the rate at which the soil can absorb the irrigated liquid. The soil intake rate decreases the longer water is applied. (See Figure 8, *land application* page 22.) The intake rate of most clay or silty soils begins to be exceeded by the time 0.5 to 0.6 inch has been applied. Continuing to irrigate beyond this amount could result in surface ponding and possible runoff, which is a violation of water quality law. Soil intake rate also depends on the crop type, plant population, soil slope, soil surface condition, and soil residue cover.

When all of the above factors are taken into account, recommended wastewater irrigation amounts for a single irrigation cycle are in the range of 0.25 to 0.75 inch per foot of effective root zone depth.

Regardless of the calculated rate, you, as the system operator, should monitor each lagoon water application to verify adequate infiltration of the water into the soil. An irrigation cycle should be stopped if ponding and runoff start to occur, or if any changes occur in drainage tile efficiency from the irrigated area.

## Understanding your system

A key element of irrigation system design is the proper combination of system components so that the system application rate does not exceed the intake rate of the soil.

**Discharge rate** is the volume of water leaving a sprinkler per unit of time. Discharge rates normally are expressed in terms of gallons per minute (gpm). Manufacturers publish discharge rates for their sprinklers as a function of the operating pressure and orifice diameter of the nozzle. You should always have a copy of the manufacturer's discharge specifications for the sprinklers in your system. Discharge characteristics of typical BIG GUN™ sprinklers are given in Table 2 (see *land application* page 23).

**Application rate** normally is expressed as unit depth of water (inch) per unit of time (usually an hour). The application rate depends upon discharge rate and coverage diameter. It is computed by first converting the discharge rate to a unit depth of water (inch) per unit of area (such as acre or square feet), then dividing by the wetted area of the sprinkler. Another important parameter is total application volume (inch), which is computed based on the amount of time the system operates at a given rate on a given field. Your target application rate represents the total volume (gallons/acre) needed to satisfy the plant-available nitrogen needs of the crop. This application rate is used for planning; rarely can you apply this much water during one irrigation cycle.

- **Determining application rates for stationary big gun and rotary**

# land application

## impact sprinklers

The application rate for stationary sprinklers is computed as follows:

1. Determine the discharge rate and wetted diameter from manufacturer's literature.
2. Determine recommended sprinkler spacing (usually 50 to 70 percent of wetted diameter). Sprinklers normally are spaced in equal multiples of 20 feet based on typical pipe section length.
3. Compute the application rate by the formula:

$$\text{Application rate, in./hr} = \frac{(96 \times \text{Discharge rate, gpm})}{(\text{Sprinkler width, ft.} \times \text{Sprinkler spacing, ft.})}$$

The application volume is then computed as the application rate multiplied by the operating time. In many cases, you will compute the desired application volume to achieve a desired amount of nitrogen application. If this is the case, you then compute the time required to operate the system to achieve the desired application volume.

- **Determining application rates for traveling gun sprinklers**

The volume of wastewater applied by a traveling gun depends on the flow rate, lane spacing, travel distance, and travel speed. A procedure to calibrate a traveling BIG GUN47 sprinkler is given below. The travel lane spacing should be approximately 70 to 80 percent of the sprinkler's wetted diameter (*see Figure 9, land application page 23*).

Determine the application depth in inches from the manufacturer's literature or Table 2 (*see land application page 23*). To determine the appropriate travel speed to deliver a known waste application depth, use the following formula:

$$\text{Travel speed} = \frac{(19.26 \times \text{Sprinkler flow rate, gpm})}{(\text{Lane spacing, ft.} \times \text{Application depth, in.})}$$

To ensure the accuracy of this calculation, occasionally measure the actual application amounts. You can do this with rain gauges or by simply measuring the depth of wastewater caught in pans or buckets placed in the irrigation field. Take several measurements at various areas during irrigation and use an average to determine the irrigation depth.

**NOTE:** Table 2 and the travel speed equation assume the gun is turning full circle. If the gun is operating at part circle, then the travel speed should be increased accordingly to provide the planned application rate.

## CALIBRATION

### Calibrating liquid tank spreaders

If the tank discharge is by gravity, a full tank will apply manure somewhat more rapidly than a nearly empty tank. Manure solids content also will also affect the application rate. Ideally, you should perform a spreader calibration for each manure source to get an idea of the variability between application rates.

- **Volume method**

The simplest way to calibrate a liquid manure spreader is to apply all the manure in a fully loaded spreader and then calculate the field area covered by that load. Divide the spreader volume by the acreage covered to get the gallons/acre. This is an average rate over the entire load. Some tank spreaders have an indicator for the manure volume remaining; calibration can then be done over a smaller portion of the load.

To determine the acreage covered, you need to know the width of the swath and the distance traveled. Swath width is the distance between the centerline locations of the spreader on two successive passes. This center-distance method accounts for any overlap or underlap. One simple way to measure the distance traveled is to mark a wheel and count revolutions during the application. (A front wheel can be used if the tractor cab obscures the view of the rear wheels.) Next, multiply the number of revolutions by the distance traveled for each revolution. The gallons applied per acre can now be calculated.

# land application

## The equation is

Gallons/acre =  
(Gallons x 43,560)/(Swath length x Swath width)

---

### Example:

You applied 3,000 gallons in one half mile pass (2,640 feet) with a spreader that covers a 15 foot swath width.

---

$$\text{Gallons/acre} = 3,000 \times 43,560 / 2,640 \times 15$$

---

$$= 3,300 \text{ gals/acre}$$

(Also see Table 3, land application page 24 for this information.)

- **Weight method**

Use scales to weigh the spreader before and after manure application; then divide the net weight by the acreage covered. To calculate the gallons/acre application rate, assume an average density (weight per gallon) of the manure. The “Liquid manure in spreader, weight method,” equation in Table 3 (see land application page 24) assumes a density of about 62 pounds/cubic foot (8.3 pounds/gallon).

- **More about liquid spreaders**

Liquid spreaders with injection toolbars should be calibrated at more than one ground speed to account for the effects of speed on injector device delivery. Consider calibrating at several tractor gear ratios and note the results. Remember that over a limited range, you can alter manure application rates by changing ground speed. You can determine a new driving speed to achieve a desired new application rate.

## The equation is

New speed =  
Original speed x (Original rate/New rate)

Or you can determine your new application rate after changing ground speeds.

## The equation is

New rate =  
Original rate x (Original speed/New speed)

Table 4 (see land application page 25) shows application rates for various swath widths, lengths, and volumes.

---

### Example:

You were driving 5 mph to apply the 3,300 gallons per acre. How fast should you go to apply 3,000 gallons per acre?

---

$$\text{New speed} = 5.0 \times 3,300 / 3,000$$

---

$$= 5.5 \text{ mph}$$

Flow sensors and flow controllers can be used to monitor and maintain your application rate, regardless of speed changes. While expensive (approximately \$6,000), the devices are a worthwhile investment if you will be applying large quantities of liquid manure. In the future they will interface with variable application rate equipment for even better control.

## Calibrating solid and semisolid manure spreaders

- **Volume method**

Box-type spreader manufacturers publish one or more spreader volumetric capacities, including the struck (level-full) capacity and the heaped capacity. Be sure to use the correct capacity number that corresponds to how the spreader is loaded. Spread a full load, noting the distance traveled and the swath width, as in the preceding section on liquid spreaders. The tons per acre application rate can be calculated



# land application

as shown below.

## The equation is

$$\text{Tons/acre} = \frac{\text{Bushels} \times 1,688}{\text{Swath length} \times \text{Width}}$$

The above equation assumes a solid manure density of 62 pounds/cubic foot. If there is much bedding in the manure, you may be applying only about 90 percent of the calculated amount because of the reduced manure density.

- **Sampled weight method**

This method samples the application rate by catching manure on one or more plastic sheets placed on the ground in the path of the spreader. You may use any size of rectangular plastic sheet, but a few convenient sizes make calculation very easy: 9 x 12 feet for light application rates, and 56 inches square or 36 x 87 inches for heavier rates. The 9 x 12 feet and 36 x 87 inches are convenient sizes if the plastic material comes in 12-foot-wide rolls.

Place a plastic sheet in the bucket or tub and weigh the sheet and container for the tare weight. Place the sheet or sheets in the field to get a representative sampling across the width of the spreader swath. Begin spreading well before you reach the plastic sheets and drive the spreader at a normal speed over the plastic. Gather up each plastic sheet, place it in the bucket or tub, weigh it, and subtract the tare weight. For best results, take the average of at least three weights. The manure application rate in tons per acre is figured from the equation in Table 3 (*see land application page 24*). Note that the weight of manure on the 9 x 12 foot sheet is divided by 5 to get the tons per acre.

Tons/acre = pounds/5  
The weight of manure on the smaller “convenience” sizes (36 x 87 inches and 56 inches square) requires no conversion.

Tons per acre =  
pounds of manure on the sheet

- **More about solid and semisolid**

## manure spreaders

Calibrate with different spreader settings and different tractor ground speeds to get a range of application rates. You should build a table of rates that will enable you to apply at nearly any rate required by the farm’s manure nutrient management plan.

## Reliability and quality of calibration results

Spreader application rates vary somewhat according to the ground slope, manure consistency, and the amount and type of bedding. The rates also vary across the swath width, with some spreaders accounting for overlap from adjacent rounds. Most equipment delivers a rate that decreases during application. Until equipment is built that regulates application rate more closely, the burden is on the operator to become familiar with the spreader’s characteristics.

A reasonable target for calibration precision is about +/- 10 to 20 percent. This target balances the uncertainty in the manure nutrient laboratory analysis with factors such as sampling error, soil variability, and differences in plant nutrient uptake. As with any sampling procedure, a single calibration reading is better than none, but multiple calibrations increase precision. However, there is a point of diminishing returns, when the labor required to perform the calibration does not pay off in improved precision.

## Calibrating irrigation systems

Manufacturers’ literature and charts apply to new equipment. Discharge rates and application rates change over time as equipment gets older and components begin to wear. Pump wear tends to reduce operating pressure and flow. Nozzle wear increases the nozzle opening, which increases the discharge rate while decreasing the wetted diameter.

Operating the system differently than assumed in the design will alter the application rate, diameter of coverage, and subsequently, the application uniformity. For example, operating the system with excessive pressure produces smaller droplets

# land application

and greater potential for drift, and accelerates wear of the sprinkler nozzle. Clogged nozzles can increase pressure. Plugged intakes or crystallized mainlines reduce operating pressure. Operating below design pressure greatly reduces the coverage diameter and application uniformity.

To ensure proper calibration and uniform coverage you should calibrate your equipment at least once every three years. To calibrate, collect, and measure flow at several locations in the application area, use a container to collect flow and determine the application rate. Rain gauges work well because they already have a graduated scale from which to read the application amount without having to perform additional calculations. However, you can use anything with a uniform opening and cross section (such as a pan or jar) if the collected liquid can be transferred to a scaled container for measuring.

To calibrate stationary sprinklers, place collection containers randomly throughout the application area at several distances from the sprinklers. For traveling guns, place containers along a transect perpendicular to the direction of pull. Place collection containers 25 feet apart along the transect on both sides of the gun cart. Compute the average application rate for all collection containers.

Also look for evidence of the application's nonuniformity. On a windless day, variation between containers of more than 30 percent is cause for concern: you should contact your irrigation dealer or technical specialist for assistance.

## ENVIRONMENTAL ISSUES

### Applying manure on frozen or snow-covered ground

Manure, especially liquid manure, should not be applied on frozen or snow-covered ground because any liquid applied to frozen ground has the potential to run off. A basic equation explains the problem:

Runoff =

Application - Infiltration - Temporary surface storage

This equation is used with all liquid application systems to prevent runoff. Iowa soils typically have infiltration rates ranging from 0.2 to 2.0 inches/hour. As long as the application rate does not exceed the infiltration rate, no runoff occurs. When the soil is frozen, however, the infiltration rate is zero, so the equation becomes

Runoff =  
Application - 0 - Temporary surface storage

Runoff =  
Application - Temporary surface storage

**NOTE:** Runoff is very likely to occur when applied on frozen soils. The greater the slope, the less the surface storage and the greater the potential for runoff.

If you must apply on frozen soils, try to make the application

- Early in the winter or
- After the snow melts in the late winter, and
- Only on flat ground.

ISU research has shown that runoff and nutrient losses are greatest from manure applied on top of snow late in the winter just before the snow melts. Much lower losses resulted from manure applied to the soil than from manure applied to the snow.

---

#### Example:

DNR has had several cases where manure was applied to frozen, snow covered ground. When the temperature rose into the 50s within several days discharges to tiles and streams resulted.

---

Separation distance is another factor to consider when applying manure to frozen ground. Except for SAFOs, Iowa law now requires a 750-foot separation distance from neighboring residences, businesses, and public areas for broadcast liquid manure from confinement operations larger than SAFOs, that is not incorporated within 24 hours.

# land application

This requirement is always in effect when the ground is frozen because you cannot incorporate the manure.

Solid manure is less risky to apply to frozen ground than liquid manure. Solid manure sometimes even acts as a mulch on tilled ground. However, risk is still involved, and the same care should be taken as with liquid manure: apply early or late in the winter season on soil rather than snow. Limit applications to flat ground.

## Controlling soil erosion

While soil erosion is a natural process, it can have detrimental effects when accelerated by human activities such as manure application. Soil erosion can cause

- The loss of the most productive part of the soil,
- The loss of applied fertilizers (including manure) and chemicals,
- Seed to be washed out or covered by sediment, and
- Sediment deposits that choke road and farm ditches, lakes, and rivers. (Sediment is the greatest pollutant by volume in Iowa.)

You can reduce soil losses to a tolerable level by using conservation farming. In some cases a system to control erosion simply may consist of a crop rotation that includes row crops, small grain, and hay. If you wish to grow all row crops, you may need to incorporate no-till farming and contour farming into your system, depending on the soil type, slope steepness, and slope length. Building terraces and contouring could enable you to do some tillage rather than no-till using the same rotation.

The Food Security Act of 1985 requires a certain level of soil erosion control of farmers who want to participate in U.S. Department of Agriculture programs. Farmers on highly erodible land (HEL), land with high erodibility due to

inherent soil erodibility, rainfall energy, and slope steepness and length, must control soil loss to at least an alternative conservation system level. Alternative conservation systems achieve significant soil loss reduction and are technically and economically feasible. They are intended only to maintain compliance for federal farm programs. Often, even more intensive systems are needed to control soil loss to tolerable levels (T). Unless erosion is controlled to T, productivity and nutrients from the manure will still be lost and water quality reduced. Systems that control soil loss to T can be developed with the Natural Resources Conservation Service or Soil and Water Conservation District.

Manure application can greatly affect soil erosion. The degree of influence generally is related to the application method and what must be done to the soil afterwards to prepare it for planting.

Liquid manure injection can disturb too much soil, cover crop residue, and leave the surface rough. This poses a problem for farmers on HEL who plan to control erosion with crop residue. Often, if they till the soil enough to work in the manure or smooth the surface for planting, there is not enough crop residue left to provide the protection they need. DNR rules require a copy of the conservation plan to accompany manure management plans that include HEL land.

Livestock producers who farm HEL fields do have options to help them maintain their eligibility for federal farm programs. They may

- Apply manure to fields that are not highly erodible (NHEL).
- Apply manure to flat areas of HEL fields.
- Use a rotation and/or additional conservation practices such as contouring or buffer strips that will allow lower residue requirements.

# land application

- Surface apply manure.
- Use equipment that injects manure but leaves the residue intact and the surface level enough to plant without further tillage. As previously noted, injection equipment has been developed that will function in a no-till system.

## Irrigation systems and neighbors

Sprinkler irrigation systems can cause serious nuisance problems even if the systems are operated in accordance with the state law.

Irrigation systems can be designed to handle liquid waste ranging from clean water containing no solids to raw manure containing more than 5 percent solids. This broad range of capability must not be exploited to the extent that the irrigation system becomes a nuisance to neighbors. You must be especially conscious of neighbors when you are irrigating liquid that has inherent odors. Raw manure is the most potent, followed by lagoon sludge, lagoon supernatant (the liquid at the top of the lagoon), and holding pond water. DNR rules require manure from pits or earthen basins to be diluted 15:1 with fresh water to be irrigated with high pressure (>80psi) systems. Five categories of nuisance or pollution potential should concern you as the irrigation system operator:

- 1. Surface water pollution due to runoff.**  
Pay close attention to soil conditions and the operation of the irrigation equipment. Apply wastewater evenly and never in amounts that cause ponding or runoff. Observe the recommended or required buffer distances from streams, roads, property lines, and designated areas.
- 2. Groundwater pollution from overapplication** causing nutrients to leach.
- 3. Overspray onto roads and other property.**  
Although the overspray might be light enough to avoid water pollution, overspray can be construed as a nuisance and a sign of poor management and an insensitive livestock facility manager. Off-site drift is a violation of DNR rules which require a minimum 100 foot separation distance

from adjacent properties.

- 4. Odor.** Be very attentive to weather conditions and timing. Select days when there will be strong sunlight in early morning and light winds.
- 5. Droplet drift.** Use low-trajectory nozzles to keep droplets low to the ground; use large tapered-bore nozzles (not ring-type) and the lowest operating pressures possible to reduce the amount of fine droplets produced.

## Prevent releases when handling pipes

Irrigation and umbilical system pipes can hold large amounts of liquid. Several releases have been recorded from drainbacks when the pipes were taken apart, or came apart accidentally. An especially sensitive situation exists when a tile intake or water body are nearby. The following table shows how much liquid pipes of different diameters can hold.

Pipe diameter	gal./ft.	gal./660 ft.	gal./mile
4	0.7	430.8	3446.5
5	1.0	673.2	5385.2
6	1.5	969.3	7754.4
7	2.0	1319.4	10555.0
8	2.6	1723.3	13786.1

A mile-long five inch diameter pipe hold over 5,000 gallons of liquid. If it held concentrated pit manure, releasing the pipe contents near any sensitive area could cause a major environmental problem.

## EXAMPLES OF ACTUAL RELEASES

Releases are nearly always unplanned. They result from mistakes, inattention to detail, or simply

# land application

failing to realize the potential consequences of actions. The following examples of releases, taken from IDNR files, are presented to help you anticipate some of the things that can happen during land application of manure.

- **Keep pipe joints as far from water resources as possible**

A custom applicator tried to repair a leaking umbilical cord joint that was located approximately 30 feet from a tile intake.

In the process, confinement hog manure entered the tile intake and resulted in a significant fish kill. In another instance a beef cattle confinement facility was transporting manure from an anaerobic lagoon to the application site across a river. A joint located within 10 feet of the river came apart, resulting in a large fish kill.

*Lesson: Keep joints and other connections as far away from water resources as possible.*

- **If a problem is identified, fix it immediately**

A producer was pumping an earthen basin. The pump hose had a hole in it and leaked manure during several days of pumping. Manure ponded in a low area and infiltrated to a nearby tile, ultimately discharging to a stream. The following year the same producer was pumping with the same hose, but had not repaired the hose. Manure leaked for several days while

pumping, ponded, and ran into a nearby tile intake in the road ditch approximately 30 feet from building. Manure discharged to a stream and resulted in a fish kill.

*Lesson: Don't ignore known problems. Protect intakes near pumping sites.*

- **Take appropriate preventative action and never leave operating equipment unattended**

A tile intake was located near a confinement building. The intake was previously plugged, but was unplugged for spring rains. Fall pumping began with the intake open. The producer temporarily left the operating pump, a hose failed, and manure from the building ran to the tile intake and was discharged to a stream.

*Lesson: Never leave equipment unattended. Protect intakes near pumping sites.*

- **Avoid overloading soil during lagoon applications**

A producer applied more than 30,000 gallons per acre from a lagoon. The soil could not hold that much liquid and manure infiltrated to tile lines and discharged to a stream.

*Lesson: Don't apply more liquid than the soil can hold. If nutrient plans call for large volumes, more than one application may be necessary.*

- **Watch the weather forecast before spreading**

A dairy operation (freestall barn) had an earthen manure storage basin sized for approximately one year of storage. In the spring the managers realized they would not make it until the fall harvest so they

# land application

planted early corn. In the fall they instructed a custom pumper to apply the contents of the basin on those 40 acres. The overall application rate was between 20,000 to 25,000 gallons per acre with a drag line hose with incorporation discs. The ground was fairly steep. Two inches of rain was received within one-half hour after application and caused substantial runoff from the field. The runoff entered a creek and caused a fish kill for almost 12 miles.

*Lesson: If a rain is predicted, delay application, especially on steep ground.*

## SUMMARY OF KEY POINTS

Next to preventing uncontrolled releases, proper land application is the most important factor affecting the environment.

- Manure rates should be determined by a manure nutrient plan.
- It is the producer's responsibility to develop and maintain the manure nutrient plan.
- It is the applicator's responsibility to apply the manure correctly.
- Advantages of injection include lower N volatilization losses, tillage benefits, reduced odor, and reduced threat of runoff losses of nutrients and microbes.
- Three broadcast systems are liquid, dry, and irrigation.
- Soil has three major components: solids, air, and water.
- Soil water content and forecast precipitation is very important in determining when and how much manure to apply.
- Soil infiltration rates decrease with increasing time during a rainfall or irrigation event.
- Discharge rate and application rate are related, but are not the same.
- Discharge rate = gallons/minute.
- Application rate = gallons/acre.
- Either weight or volume can be used to calibrate spreaders.
- Don't apply more liquid than the soil can hold.
- Runoff = application - temporary surface storage - infiltration. If infiltration is zero, runoff will result when the application is greater than the surface storage.
- Soil erosion causes losses in fields and pollution in ditches, lakes, and rivers.
- Manure applied to the surface and incorporated or applied by injection can reduce residue cover and affect conservation compliance on highly erodible land (HEL). A disadvantage of injection is reduced crop residue cover, resulting in the increased threat of erosion.
- Conservation practices are available and can be applied to allow producers to apply manure and maintain compliance.
- Equipment is continually being developed and improved to inject manure and maintain residue cover.
- Watch the weather forecast. Don't try to "beat" the rain.

## References

Block, W.A., R.K. Knipe, and S.L. Hollister. 1995. *Manure application on highly erodible land. ASAE Paper no. 95-2412.*

# *land application*

---

*Block, W.A., R.K. Knipe, and D.C. Feltes. 1994.  
Manure injection with conservation compliance.  
Illinois Swine Seminar Proceedings 1994,  
University of Illinois Cooperative Extension  
Service.*

# *land application*

---



# *land application*

---

# land application

**FIGURE 1**

**IDEAL PARAMETERS OF MANURE INJECTION DESIGN**

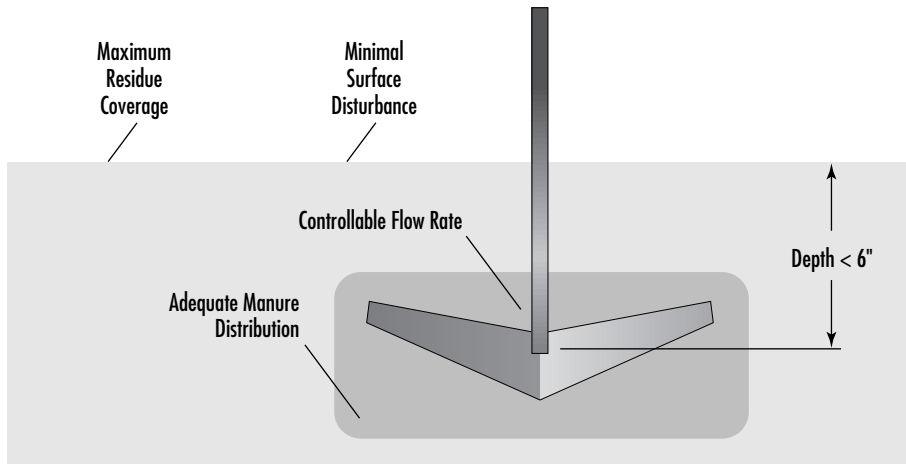
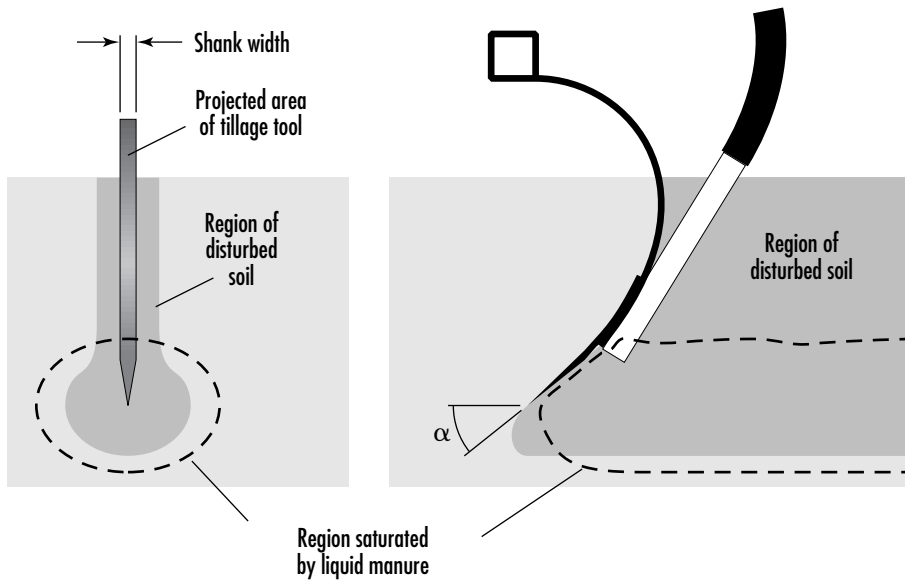

**FIGURE 2**

**CHISEL POINT-TYPE INJECTOR**

FRONT VIEW

SIDE VIEW



# land application

**FIGURE 3**

**SWEEP-TYPE INJECTOR**

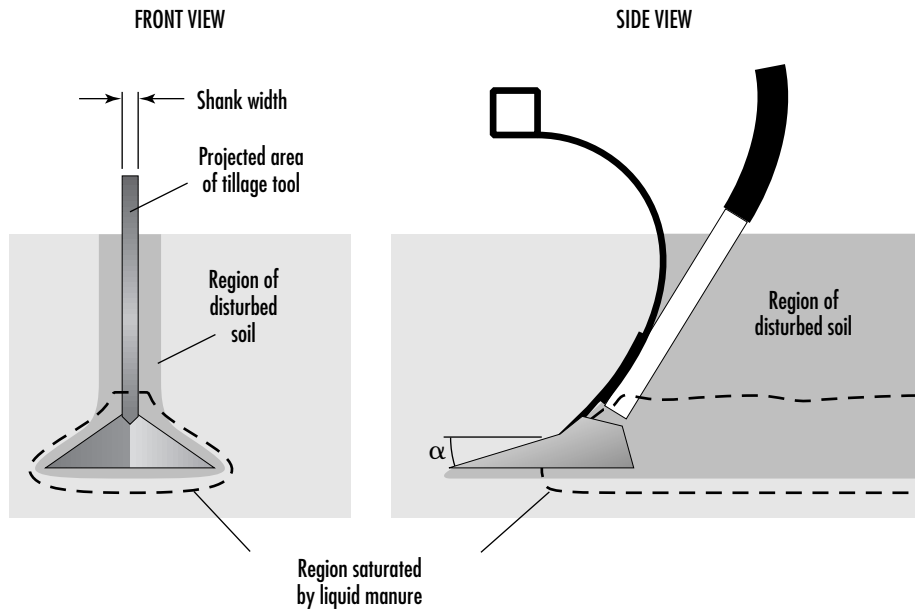

**FIGURE 4**

**SWEEP-TYPE INJECTOR WITH COULTER AND CLOSING DISKS**

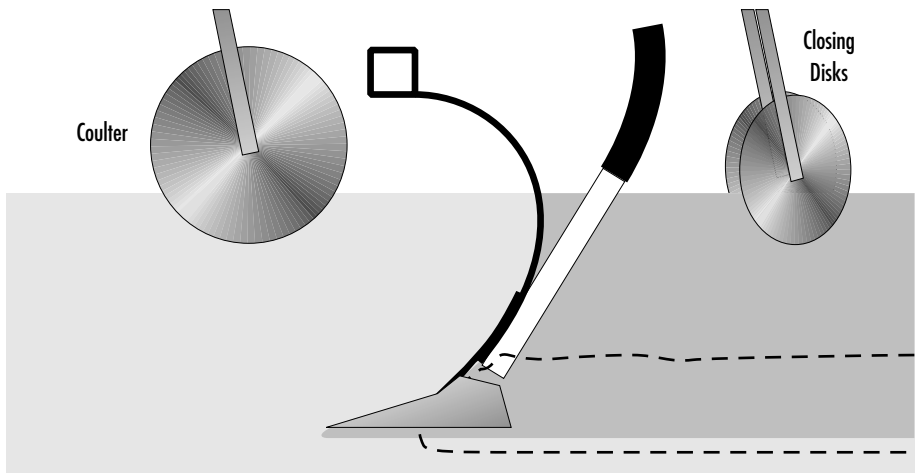

# land application

**FIGURE 5**

**RESIDUE MEASUREMENTS AT ISU MANURE APPLICATION FIELD DAYS HAS SHOWN THAT UP TO 89 PERCENT OF THE RESIDUE CAN BE RETAINED BY THE SUKUP AND YETTER NO-TILL INJECTORS AND THE FARMSTAR NO-TILL INJECTOR.**



# land application

**FIGURE 6**

**MANY OF THE SWEEPS RETAINED 60 PERCENT RESIDUE COVERAGE.**



**FIGURE 7**

**COVERING DISKS PERFORM WELL IN RESIDUE. RESIDUE COVERAGE DEPENDS ON HOW DEEP THEY ARE RUN.**



# land application

**TABLE 1**

**BEHAVIOR OF SOIL AT SELECTED SOIL-WATER DEPLETION AMOUNTS**

AVAILABLE WATER REMAINING IN THE SOIL	SOIL TYPE	
	SANDS	LOAMY SAND/SANDY LOAM
Soil saturated, wetter than field capacity	Free water appears when soil ball is squeezed	Free water appears when soil ball is squeezed
100% available (field capacity)	When soil ball is squeezed, wet outline on hand but no free water	When soil ball is squeezed, wet outline on hand but no free water
75 to 100%	Sticks together slightly	Forms a ball that breaks easily
50 to 75%	Appears dry; will not form a ball	Appears dry; will not form a ball
Less than 50%	Flows freely as single grains	Flows freely as single grains

**FIGURE 8**

**TYPICAL INFILTRATION RATE CURVE**

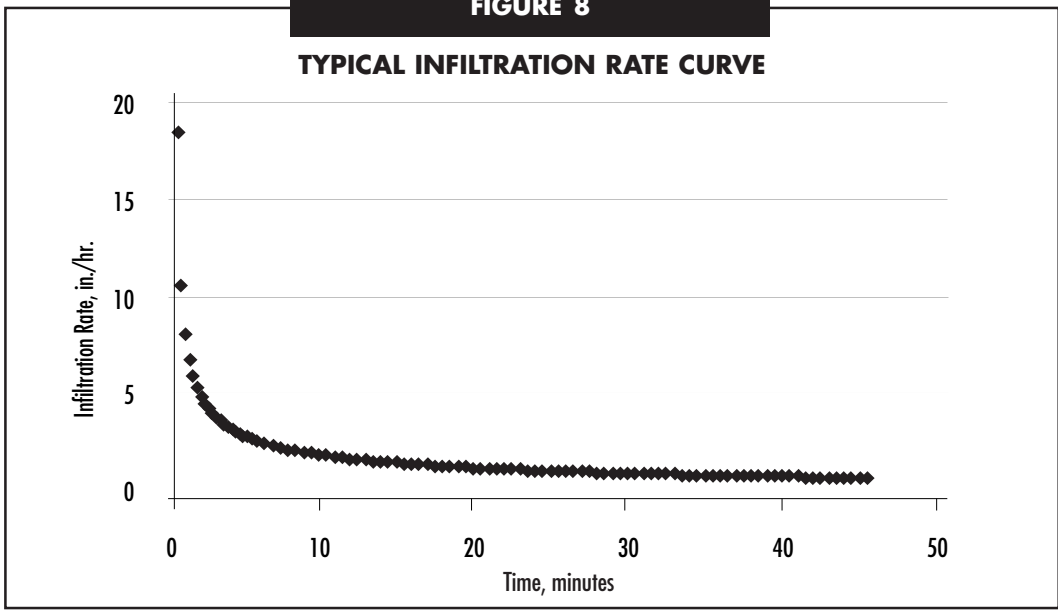

# land application

**TABLE 2\***

**GENERAL FLOW RATES AND COVERAGE DIAMETER FOR  
BIG GUN™ STATIONARY SPRINKLERS**

PRESSURE DIA. (FT.)	0.50		0.75		1.00		1.50		2.00	
	(PSI)	GPM	DIA. (FT.)	GPM	DIA. (FT.)	GPM	DIA. (FT.)	GPM	DIA. (FT.)	GPM
50	50	205	115	256	204	300	-	-	-	-
60	55	215	126	267	224	316	515	430	912	512
70	60	225	136	283	243	338	555	450	980	528
80	64	235	146	295	258	351	590	470	1047	548
90	68	245	155	306	274	362	625	485	1105	568
100	72	255	163	316	289	372	660	500	1167	592
110	76	265	171	324	304	380	695	515	1220	607

\* Assumes gun is turning full circle.

**FIGURE 9**

**TYPICAL LAYOUT OF A TRAVELING GUN IRRIGATION SYSTEM**

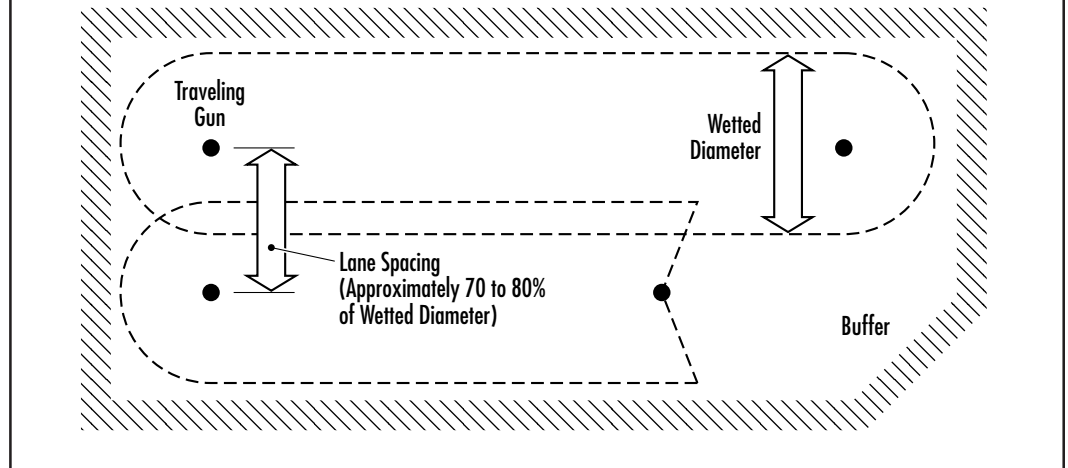

# land application

**TABLE 3**

**MANURE SPREADER CALIBRATION**

MANURE SOURCE	KNOWN	MEASURE/CALCULATE	RESULT
Liquid manure in tank	1. Volume of manure tank in gallons	<u>Gallons</u>	Gallons per acre application rate
	2. Acreage over which manure is spread at even rate	<u>Acres</u>	
Liquid manure in spreader; volume method	1. Volume of manure spread in gallons	<u>Gallons x 43,560</u>	Gallons per acre application rate
	2. Distance driven and width spread, feet	<u>Distance x width</u>	
Liquid manure in spreader weight method	1. Pounds spread	<u>Pounds x 5,248</u>	Gallons per acre application rate (Assumes 62 pounds/cubic foot density)
	2. Distance driven and width spread, feet	<u>Distance x width</u>	
Solid manure in spreader; spreader volume method	1. Spreader struck-level volume, in bushels	<u>Bushels x 1,688</u>	Tons per acre application rate (Assumes 62 pounds/cubic foot density)
	2. Distance driven and width spread, feet	<u>Distance x width</u>	
Solid manure in spreader; plastic sheet weight method	1. Area of plastic sheet, in square feet	<u>Net weight, pounds x 21.78</u>	Tons per acre application rate
	2. Tare weight of manure on sheet after drive-over	<u>Area of plastic sheet, square feet</u>	
	Shortcut method:	<u>Net weight, pounds</u>	Tons per acre application rate
	Use 9 x 12 foot sheet	5	
	Shortcut Method:	<u>Net weight, pounds</u>	Tons per acre application rate



# land application

**TABLE 4**

**LIQUID MANURE APPLICATION RATES**

		Distance of Travel, feet .....							
TANK SIZE (Gallons)	WIDTH OF Spread (ft.)	660	990	1320	1650	1980	2640	3900	5280
		GALLONS PER ACRE APPLIED							
1,000	10	6,600	4,400	3,300	2,640	2,200	1,650	1,117	825
	15	4,400	2,933	2,200	1,760	1,467	1,100	745	550
	25	2,640	1,760	1,320	1,056	880	660	447	330
1,500	10	9,900	6,600	4,950	3,960	3,300	2,475	1,675	1,238
	15	6,600	4,400	3,300	2,640	2,200	1,650	1,117	825
	25	3,960	2,640	1,980	1,584	1,320	990	670	495
2,000	10	13,200	8,800	6,600	5,280	4,400	3,300	2,234	1,650
	15	8,800	5,867	4,400	3,520	2,933	2,200	1,489	1,100
	25	5,280	3,520	2,640	2,112	1,760	1,320	894	660
2,400	10	15,840	10,560	7,920	6,336	5,280	3,960	2,681	1,980
	15	10,560	7,040	5,280	4,224	3,520	2,640	1,787	1,320
	25	6,336	4,224	3,168	2,534	2,112	1,584	1,072	792
2,800	10	18,480	12,320	9,240	7,392	6,160	4,620	3,127	2,310
	15	12,320	8,213	6,160	4,928	4,107	3,080	2,085	1,540
	25	7,392	4,928	3,696	2,957	2,464	1,848	1,251	924
3,000	10	19,800	13,200	9,900	7,920	6,600	4,950	3,351	2,475
	15	13,200	8,800	6,600	5,280	4,400	3,300	2,234	1,650
	25	7,920	5,280	3,960	3,168	2,640	1,980	1,340	990
3,200	10	21,120	14,080	10,560	8,448	7,040	5,280	3,574	2,640
	15	14,080	9,387	7,040	5,632	4,693	3,520	2,383	1,760
	25	8,448	5,632	4,224	3,379	2,816	2,112	1,430	1,056
3,600	10	23,760	15,840	11,880	9,504	7,920	5,940	4,021	2,970
	15	15,840	10,560	7,920	6,336	5,280	3,960	2,681	1,980
	25	9,504	6,336	4,752	3,802	3,168	2,376	1,608	1,188
4,000	10	26,400	17,600	13,200	10,560	8,800	6,600	4,468	3,300
	15	17,600	11,733	8,800	7,040	5,867	4,400	2,978	2,200
	25	10,560	7,040	5,280	4,224	3,520	2,640	1,787	1,320
4,200	10	27,720	18,480	13,860	11,088	9,240	6,930	4,691	3,465
	15	18,480	12,320	9,240	7,392	6,160	4,620	3,127	2,310
	25	11,088	7,392	5,544	4,435	3,696	2,772	1,876	1,386
4,800	10	31,680	21,120	15,840	12,672	10,560	7,920	5,361	3,960
	15	21,120	14,080	10,560	8,448	7,040	5,280	3,574	2,640
	25	12,672	8,448	6,336	5,069	4,224	3,168	2,144	1,584
5,000	10	33,000	22,000	16,500	13,200	11,000	8,250	5,585	4,125
	15	22,000	14,667	11,000	8,800	7,333	5,500	3,723	2,750
	25	13,200	8,800	6,600	5,280	4,400	3,300	2,234	1,650
6,000	10	39,600	26,400	19,800	15,840	13,200	9,900	6,702	4,950
	15	26,400	17,600	13,200	10,560	8,800	6,600	4,468	3,300