



Produced by:

IOWA STATE UNIVERSITY
University Extension



In cooperation with:

Written by:

Jeff Lorimor extension agricultural and biosystems engineer
Kris Kohl extension agricultural and biosystems field engineer
Randy Killorn extension agronomist
Bill Lotz extension crop field specialist
Paul Miller Natural Resource Conservation Service

Edited by:

Tracy Peterson
Elaine Edwards ISU Extension Communication Systems
Bonnie Harmon

Designed by:

Julie Mangels Juls Design, Ankeny, Iowa

A special thanks to:

North Carolina State University and the University of Illinois. Some of the materials in this manual were adopted from *Certification Training for Operators of Animal Waste Management Systems Manual*, published by North Carolina State University and *Certified Livestock Managers' Manual*, published by the University of Illinois. Reviewed by Ubbo Agena and field staff, Iowa Department of Natural Resources, and Gerald Miller and Jim Johnson, Iowa State University Extension.

...and justice for all
The U.S. Department of Agriculture (USDA) prohibits discrimination in all its programs and activities on the basis of race, color, national origin, gender, religion, age, disability, political beliefs, sexual orientation, and marital or family status. (Not all prohibited bases apply to all programs.) Many materials can be made available in alternative formats for ADA clients. To file a complaint of discrimination, write USDA, Office of Civil Rights, Room 326-W, Whitten Building, 14th and Independence Avenue, SW, Washington, DC 20250-9410 or call 202-720-5964.

Issued in furtherance of Cooperative Extension work, Acts of May 8 and June 30, 1914, in cooperation with the U.S. Department of Agriculture. Stanley R. Johnson, director, Cooperative Extension Service, Iowa State University of Science and Technology, Ames, Iowa.

December 1999
File: Environmental Quality 1-4
[E]



table of contents

INTRODUCTION

introduction page

Manure—an asset	1
Manure risks	1
Land application errors	2
Environmental and financial benefits	2

WATER QUALITY

water quality page

Water quality concepts	1
Conditions which impact water quality	1
• Immediate effects	
• Manure nutrients	
• Other manure components	
• Soil characteristics	
• Runoff	
Groundwater considerations	3
• Dependence on groundwater	
• The aquifer	
• Nitrate in drinking water	
Summary of key points	4

STORAGE

storage and handling page

System descriptions	1
• Formed tanks	
• Earthen manure storage	
• Lagoons	
Dry manure storage	2
Management requirements	3
Storage capacity calculations	4
• Rectangular pits	
• Round pits	
• Earthen basins	
Summary of key points	5

table of contents

NUTRIENT MANAGEMENT

nutrient management page

Managing manure nutrients for crop production

Determining nutrient content	1
Crop availability	2
• Nitrogen availability	
• Phosphorus availability	
• Potassium availability	
Nutrient requirements for crop production	3
• Method 1 for nitrogen	
• Method 2 for nitrogen	
Allocating manure to fields	4
Scheduling application	5
Summary of key points	5

LAND APPLICATION

land application page

Environmental safety	1
• Manure application guidelines	
Liquid manure application systems	2
• Injection systems	
• Broadcast systems	
• Irrigation systems	
Determining the proper rate	3
Soil-water relationships	5
• Estimating soil-water content	
• Scheduling irrigation	
• Understanding your system	
- Determining application rates for stationary big gun and rotary impact sprinklers	
- Determining application rates for traveling gun sprinklers	
Calibration	9
• Calibrating liquid tank spreaders	
- Volume method	
- Weight method	
- More about liquid spreaders	
• Calibrating solid and semisolid manure spreaders	
- Volume method	
- Sampled weight method	
- More about solid and semisolid manure spreaders	
• Reliability and quality of calibration results	
• Calibrating irrigation systems	

table of contents

Environmental issues	12
• Applying manure on frozen or snow-covered ground	
• Controlling soil erosion	
• Irrigation systems and neighbors	
• Prevent releases when handling pipes	
Example of actual releases	15
Summary of key points	17

EMERGENCIES AND SAFETY

emergencies and safety page

Emergency action plans and safety

Emergency action plans	1
Personal safety	4
• Manure gases	
- Hydrogen sulfide	
- Methane	
• First aid for victims of manure gas asphyxiation	
• Effect of air quality on human health	
Summary of key points	7

APPLICATOR RULES

applicator rules page

Manure applicator certification	1
Manure management plans	1
Records	5
Manure application separation distances and restrictions	5
Adjacency and building separation distances	6
• Separation distances	
• Right-of-way separation distance	
• Water course separation distances	
Confinement animal feeding operation construction permits	7
Summary of key points	8

table of contents

RECORD KEEPING

record keeping page

Nitrogen records	1
Land application records	1
Field sketches	2
Sample records	2

OTHER RESOURCES

other resources page

Iowa State University Extension field specialists/agricultural engineers	1
Iowa State University Extension field specialists/crops	1
Natural Resources Conservation Service	3
• NRCS state office	
• NRCS area offices	
Iowa Department of Natural Resources	3
^a IDNR Environmental Protection Division field offices	
Manure and soil testing laboratories	4
• Soil and manure analysis	
• Soil and biosolids analysis	
• Manure analysis	
• Soil testing	

table of contents

TABLES AND FIGURES		<i>page</i>
Uncontrolled discharges (<i>figure 1</i>)	<i>introduction 3</i>
Number of uncontrolled releases each year caused by land application errors (<i>table 1</i>)	<i>introduction 3</i>
The hydrologic cycle (<i>figure 1</i>)	<i>water quality 5</i>
Potential sources of nonpoint source pollution (<i>figure 2</i>)	<i>water quality 5</i>
Rectangular pit capacity gallons — 6 feet of liquid (<i>table 1</i>)	<i>storage and handling 6</i>
Rectangular pit capacity gallons — 8 feet of liquid (<i>table 2</i>)	<i>storage and handling 6</i>
Rectangular pit capacity gallons — 10 feet of liquid (<i>table 3</i>)	<i>storage and handling 7</i>
Round pit capacity gallons — various depths (<i>table 4</i>)	<i>storage and handling 7</i>
Earthen basins capacity gallons — pumpout depth = 6 feet (<i>table 5</i>)	<i>storage and handling 8</i>
Earthen basins capacity gallons — pumpout depth = 8 feet (<i>table 6</i>)	<i>storage and handling 8</i>
Earthen basins capacity gallons — pumpout depth = 10 feet (<i>table 7</i>)	<i>storage and handling 9</i>
Earthen basins capacity gallons — pumpout depth = 12 feet (<i>table 8</i>)	<i>storage and handling 9</i>
Corn N Requirements (<i>figure 1</i>)	<i>nutrient management 6</i>
Plant available nutrients excreted by livestock in Iowa in 1990 (<i>table 1</i>)	<i>nutrient management 6</i>
Nutrients in animal manure (<i>table 2</i>)	<i>nutrient management 7</i>
Nutrients excreted by animals (<i>table 3</i>)	<i>nutrient management 8</i>
Correction factors to account for nitrogen volatilization losses during land application of animal manure (<i>table 4</i>)	<i>nutrient management 9</i>
Nutrient removal for Iowa crops (<i>table 5</i>)	<i>nutrient management 9</i>
Nitrogen fertilizer recommendations for manured soils and corn after alfalfa (<i>table 6</i>)	<i>nutrient management 10</i>
Priority ranking of fields for animal manure application based on soil test for phosphorus and potassium and the crop to be grown (<i>table 7</i>)	<i>nutrient management 10</i>

table of contents

TABLES AND FIGURES CONT.

page

Ideal parameters of manure injection design (figure 1)	land application 18
Chisel point-type injector (figure 2)	land application 18
Sweep-type injector (figure 3)	land application 19
Sweep-type injector with coulter and closing disks (figure 4)	land application 19
Residue measurements at ISU manure application field days has shown that up to 89 percent of the residue can be retained by the Sukup and Yetter no-till injector and the Farmstar no-till injector. (figure 5)	land application 20
Many of the sweeps retained 60 percent residue coverage. (figure 6)	land application 21
Covering disks perform well in residue. Residue coverage depends on how deep they are run. (figure 7)	land application 21
Behavior of soil at selected soil-water depletion amounts (table 1)	land application 22
Typical infiltration rate curve (figure 8)	land application 22
General flow rates and coverage diameter for Big Gun™ stationary sprinklers (table 2)	land application 23
Typical layout of a traveling gun irrigation system (figure 9)	land application 23
Manure spreader calibration (table 3)	land application 24
Liquid manure application rates (table 4)	land application 25
Field office locations of Environmental Protection Division (chart 1)	emergency and safety 3
Characteristics and effects of gasses produced in livestock buildings and manure storage structures (table 1)	emergency and safety 8
Health symptoms of Iowa swine facility workers (table 2)	emergency and safety 8
Facility weight capacity for swine (table 1)	applicator rules 10
Facility weight capacity for bovine (table 2)	applicator rules 10
Facility weight capacity for poultry (table 3)	applicator rules 10
Crop nitrogen usage rate factor (table 4)	applicator rules 11

table of contents

TABLES AND FIGURES CONT.

page

Required separation distance (for spring irrigation) from actual wetted perimeter to residence, commercial enterprise, religious institution, educational institution, or public use area (table 5)	applicator rules 11
Minimum distance requirements which allows two sites to be considered as separate operations (table 6)	applicator rules 11
Separation distance requirements for structures for non-bovine operations (table 7)	applicator rules 12
Separation distance requirements for structures for bovine operations (table 8)	applicator rules 13
Minimum thresholds for construction permits (table 9)	applicator rules 14
Indemnity fees charged to producers who file manure management plans after 1/1/99 (table 10)	applicator rules 14
Application data (worksheet)	record keeping 3
Weather data (worksheet)	record keeping 4
Field sketches (worksheet)	record keeping 5
Testing results (worksheet)	record keeping 6
Manure inventory (worksheet)	record keeping 7
Field application inventory (worksheet)	record keeping 8



*I*owa's manure law requires manure applicators to become certified by March 1, 1999. The 1998 Iowa Legislature included the certification provisions as part of House File 2494. As Livestock facilities become larger, there may be increasing pressure to apply manure faster, under poorer weather conditions, and at higher rates than are environmentally friendly. Manure applicator certification is designed to help you use manure as an asset and avoid water quality problems due to improper application. Reported releases and discharges to the state's rivers, stream, and lakes have increased since 1992.

MANURE—AN ASSET

Manure has been applied to agricultural land for many years. People discovered long ago that manure makes crops grow better and produce more. Long-term research on manure application (dating back more than 100 years) clearly shows that manure applications at the right rates are good for the soil. Manure increases organic matter, helps develop better soil structure, increases cation exchange capacity, promotes better drainage, increases the number of microorganisms, and generally improves the “tilth” of the soil. Soils with a long-term history of being manured have been shown to be superior to soils that were not manured, or were fertilized with commercial fertilizers.

Manure nutrients from liquid swine pits may be worth \$20 per 1,000 gallons or more. By replacing commercial fertilizer with manure, producers can save up to \$40 to \$60 per acre.

In recent years we have become increasingly aware that manure also can have negative effects on the environment. Uncontrolled releases of liquid manure from pits or lagoons can cause immediate fish kills and loss of other aquatic life. And long-term, over-application of manure can cause buildups of nutrients in the soil, particularly phosphorus, that can ultimately cause surface water quality problems.

The key to maintaining manure as an asset and a valuable resource is careful handling and applying at proper rates. That’s what manure applicator certification is about—helping you, as a manure manager, do a better job so the manure you manage remains an asset, rather than becoming

a liability.

MANURE RISKS

IDNR records show approximately 86 uncontrolled discharges to surface waters were reported between February 1992 and May 1998. That’s an average of 14 per year, and the trend is increasing (see Figure 1 on introduction page 3).

This may reflect a greater number of uncontrolled releases and discharges or it may simply reflect greater public scrutiny or reporting. During those six years, 32 fish kills occurred. Not all releases resulted in pollution of state waters, but all were significant enough to require IDNR investigation and follow-up. Of course, unreported discharges are not shown. The reported discharges occurred from the following types of facilities: earthen storage structures, 42; formed pits, 20; open feedlots, 24.

Sixteen discharges were due to poor construction, such as failing to remove existing field tiles, leaking or plugged lines or valves, or leaving organic matter in earthen berms during construction. Twenty-six releases were caused by poor management or lack of attention, such as leaking waterers or ruptured water lines that caused pits to fill and overtop, running out of storage capacity in pits or lagoons, or even intentional dumping. Overtopping of earthen basins, formed pits, and lagoons all occurred, as did discharges from open feedlots due to precipitation events.

introduction

LAND APPLICATION ERRORS

Land application errors caused 30 releases, more than either construction or management errors. Releases during land application resulted from applying manure to frozen soils, irrigation line separations during pumping, pumps being left on too long, simply applying more manure than the soil could hold, and precipitation immediately after manure application. While the number of releases during land application is not high on a statewide basis, the records confirm these releases often reach streams or rivers, causing fish kills and other environmental damage. The number of releases during land application each year also has been rising (*See Table 1 on introduction page 3.*)

ENVIRONMENTAL AND FINANCIAL BENEFITS

Manure can be managed to minimize environmental impacts while optimizing economic benefits for all parties. Longtime research clearly shows that properly applying manure to land is beneficial to the soil and water in both the short and long term.

The following material is presented to help you become legally certified to apply manure in Iowa and help you understand how to manage manure correctly so that it is an asset, rather than a liability.

introduction

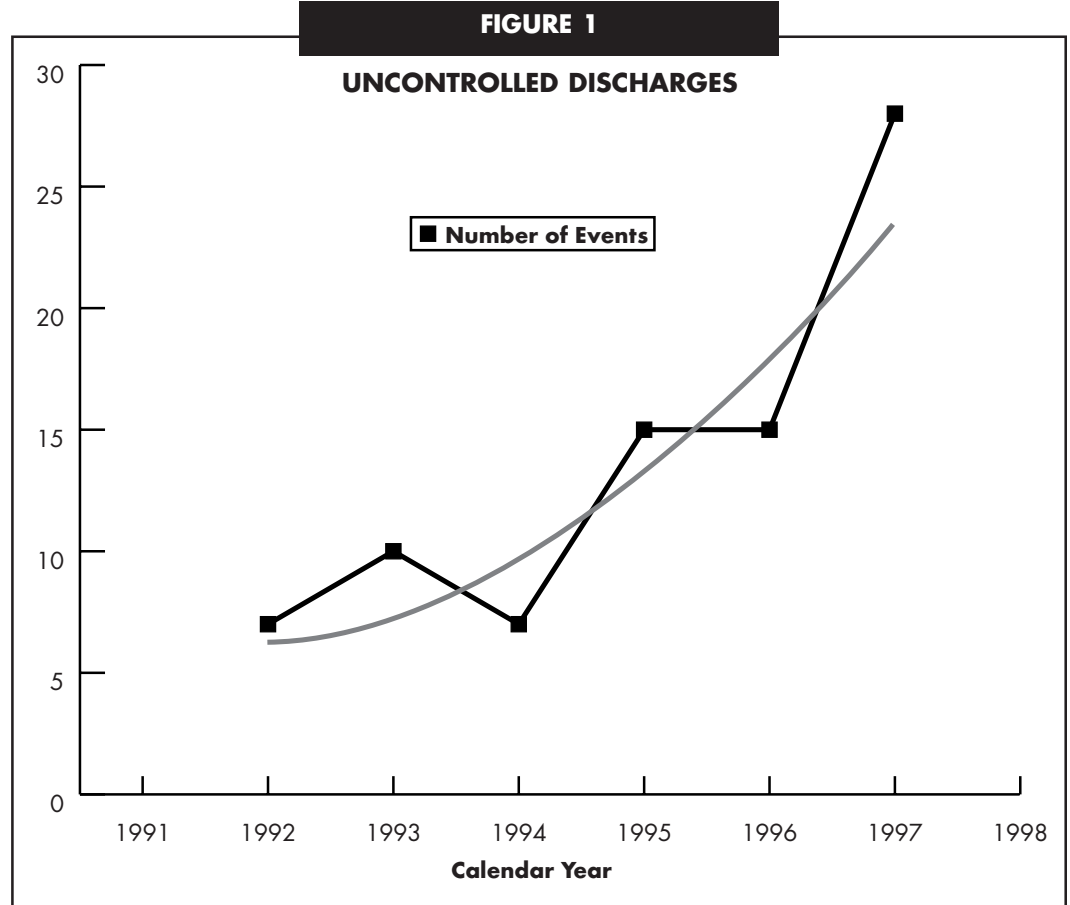

IDNR-recorded uncontrolled manure and lagoon effluent releases.

TABLE 1

**NUMBER OF UNCONTROLLED
RELEASES EACH YEAR CAUSED
BY LAND APPLICATION ERRORS**

YEAR	NUMBER OF RELEASES
1992	2
1993	5
1994	1
1995	5
1996	5
1997	12



water quality

All wastes and wastewaters must be handled properly to protect the environment and public health. Runoff from feedlots and confined animal operations has the potential to harm both groundwater, which includes your drinking water and that of your neighbors, and surface water which many urban Iowans depend on for drinking water, and the plant and animal life that depends on it.

WATER QUALITY CONCEPTS

In order to understand water quality you must know that all water falling as rain or snow evaporates, soaks into the soil, or runs off the land. Water that does not evaporate either moves as surface runoff into streams, rivers, and lakes or percolates through the soil. Water on the land in streams and lakes is called surface water, while water under the surface is called groundwater. The movement of water on the land, in the ground, and through the air is termed the hydrologic cycle (*see Figure 1, water quality page 5*).

Manure application acts much the same way as natural rainfall. Runoff from a manure application site is not acceptable. Therefore, the operator must match his or her manure application rate to

- The nutrient needs of the crop and
- The rate at which the soil will accept and hold the manure.

Point source pollution is a single identifiable source of pollution, such as a pipe through which factories or treatment plants discharge treated wastewater into a surface water. Open feedlots and confinement feeding operations are considered point sources. A permit is required for any point source discharge of pollutants into surface waters. However, Iowa law requires confinement feeding operations to retain all manure between periods of land application.

Nonpoint source pollution (NPS) is more difficult to trace to its point of origin because it takes place over a broad area and results in the release of pollutants from many different locations. Runoff from agriculture, crop and pasture land, forestry, highways, and residential and urban development are examples of nonpoint source pollutants (*see Figure 2, water quality page*

5).

CONDITIONS WHICH IMPACT WATER QUALITY

Immediate effects

The effects of manure spills on surface water quality can be immediate. Excessive levels of ammonia and/or biological oxygen demand (BOD) can quickly kill aquatic life. As a result, fish kills are common when manure discharges occur. Fish and other organisms are very sensitive to ammonia which is present in manure in high concentrations. High BODs quickly use up the oxygen in the water and simply cause the fish to suffocate. The ability of water to hold oxygen decreases as the water temperature increases. When water levels are low and temperatures are high, such as in the late summer, streams and lakes are especially sensitive to pollutants.

Natural sinkholes and agricultural drainage wells allow aquifers to be affected immediately by uncontrolled releases or mismanaged manure. They provide direct connections between the soil surface and adjacent aquifers. Extra care is necessary to protect them.

Manure nutrients

Eutrophication is the slow, natural nutrient enrichment of streams and lakes that is responsible for the “aging” of ponds, lakes, and reservoirs. Excessive amounts of nutrients from point and nonpoint source pollution, especially nitrogen and phosphorus, speed up the eutrophication

water quality

process. Rapid eutrophication usually is associated with increased algal growth. As more and more algae grow and then decompose, they deplete the dissolved oxygen in slow-moving water. This condition may result in fish kills, offensive odors, and reduced attractiveness of the water for recreation and other public uses. However, this condition occurs only when *excessive* nutrients are present. A certain amount of nitrogen and phosphorus is essential for any life to exist in water.

Other manure components

Other manure components also may affect water quality. Animal manure contains bacteria, viruses, ammonia, organics, and a variety of other chemicals which may impact plant and animal life in the water. Additionally, the bacteria and viruses have the potential to infect humans who use the water for fishing, recreation, or drinking water.

Soil characteristics

Excessive manure applications have the potential to harm groundwater as well. The soil is a very effective manure treatment system if wastes are applied at proper rates, preventing the soil from being overloaded. Groundwater contamination occurs when the soil has been overloaded or when measures have not been taken to adequately prevent manure from entering wells, sinkholes, or other conduits leading directly to ground water. The soil is a controlling factor in the groundwater recharge process because it may hold the water in soil pores, release it to plant roots or the atmosphere, or allow it to pass through to the lower layers. While the soil can filter pollutants and prevent them from reaching groundwater, it varies tremendously in its adsorptive, or filtering, capacity. As a result, under some conditions, pollutants may take months or years to move from the land surface to the groundwater. In other cases they can flow almost directly into the groundwater. To determine the potential for

groundwater contamination in a given situation it is essential that you understand soil characteristics.

Depth to groundwater is important because it determines the volume of soil through which a pollutant must travel before reaching the groundwater. It also helps determine the amount of time that a pollutant is in contact with the soil. The processes of filtration, absorption and adsorption, biodegradation, and volatilization operate effectively where the soil is fairly deep. Conversely, shallow soils can adsorb only a limited amount of pollutants. The pollution potential increases where the soils are thin and the underlying bedrock is permeable, or where the water table is near the surface.

Soil texture is determined by the soil's relative proportion of sand, silt, and clay. Sandy soils allow water to drain rapidly; therefore, they do not retain the manure materials (nutrients) so they can be used by the crops. Soils with more clay, which are sticky when wet and hard and clumpy when dry, are better suited for holding the manure until the nutrients can be used by the crops. As a result, groundwater contamination is less likely in clay soils.

Organic matter has a very large adsorptive capacity for most pollutants. It usually is concentrated in the topsoil. Maintaining an active organic component in the topsoil through good soil and crop management enhances the soil's capacity to serve as a filter.

Runoff

Runoff from a site is determined by the slope of the land, the soil texture, and the thickness and type of cover crop. Soils heavy in clay have a much lower capacity to absorb water quickly than do sandy soils. Steeper slopes increase runoff. Using cover crops and the best management practices (BMPs) will enhance a site's ability to absorb water and reduce the possibility of runoff. While infiltration rate estimates are available, you must both tailor the manure application rate to your individual situation, based on your experience, and closely monitor the actual

water quality

application to ensure there is no runoff.

GROUNDWATER CONSIDERATIONS

Groundwater is an essential natural resource. Ninety percent of rural residents and 50 percent of the total U.S. population depend on groundwater for their drinking water. Eighty percent of Iowans rely on groundwater for their needs. Concern about its quality and potential contamination has made groundwater protection a national issue.

Dependence on groundwater

There are several reasons for the widespread dependence on groundwater. In its natural state, groundwater usually is excellent in quality and can be used without costly treatment or purification. It can be inexpensively tapped next to the point of use, thereby saving the cost of transporting water over long distances. For rural residents relying on individual wells and for public water supplies in some communities, groundwater often is the only available water supply.

The aquifer

Groundwater does not consist of large underground lakes or streams, but instead is the water in spaces within rock fractures or between particles of sand, gravel, silt, or clay. The underground formation through which groundwater moves is called an aquifer (*see Figure 2, water quality page 5*). Furthermore, groundwater does not move rapidly in the aquifer. It may move only a few feet per month or even per year, whereas surface streams flow several feet per second.

Nitrate in drinking water

Excessive nitrate (NO_3) in drinking water can cause human and animal health problems, particularly for small babies. Over applying nitrogen fertilizers or manure on the soil is one source of excess nitrate in groundwater. Research clearly shows that properly manured soils have low nitrate in the shallow groundwater. If excess N is applied as either manure or commercial N, nitrate will likely increase in groundwater. The United States Public Health Service has established a specific standard of 10 milligrams of nitrate nitrogen per liter (10 ppm $\text{NO}_3\text{-N}$) as the maximum concentration that is safe for humans to drink.

SUMMARY OF KEY POINTS

- All manure and wastewater must be handled properly to protect the environment.
- Point source pollution is pollution from a single identifiable source.
- Nonpoint source pollution takes place over a broad area.
- Ammonia and BOD from manure spills can cause immediate water quality problems resulting in fish kills and the loss of other aquatic life.
- Sinkholes and ag drainage wells are especially sensitive to manure spills or mismanagement.
- Nutrients in manure, especially phosphorus and nitrogen, can move into surface water and cause eutrophication. This can result in a low oxygen content in the water which

water quality

can cause fish kills, offensive odors, and unsightliness.

- Manure contains bacteria, viruses, ammonia, organics, and a variety of other chemicals which may immediately impact plant and animal life in surface waters.
- The nitrogen in manure can be converted into nitrate in soils. Nitrate can leach into groundwater, creating a health hazard for humans and livestock.
- Groundwater is an essential natural resource. Eighty percent or more of Iowa's population, and fifty percent of the U.S. population rely on groundwater for their drinking water.
- Mismanagement of animal manure increases the potential for environmental contamination.

water quality

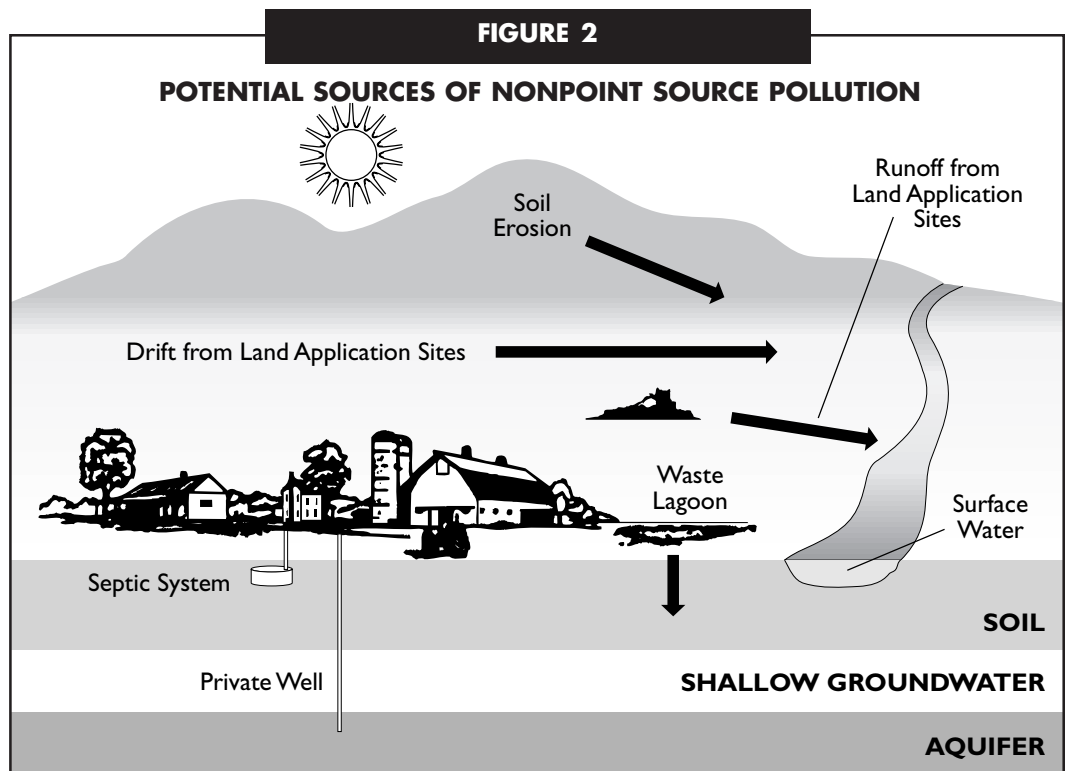
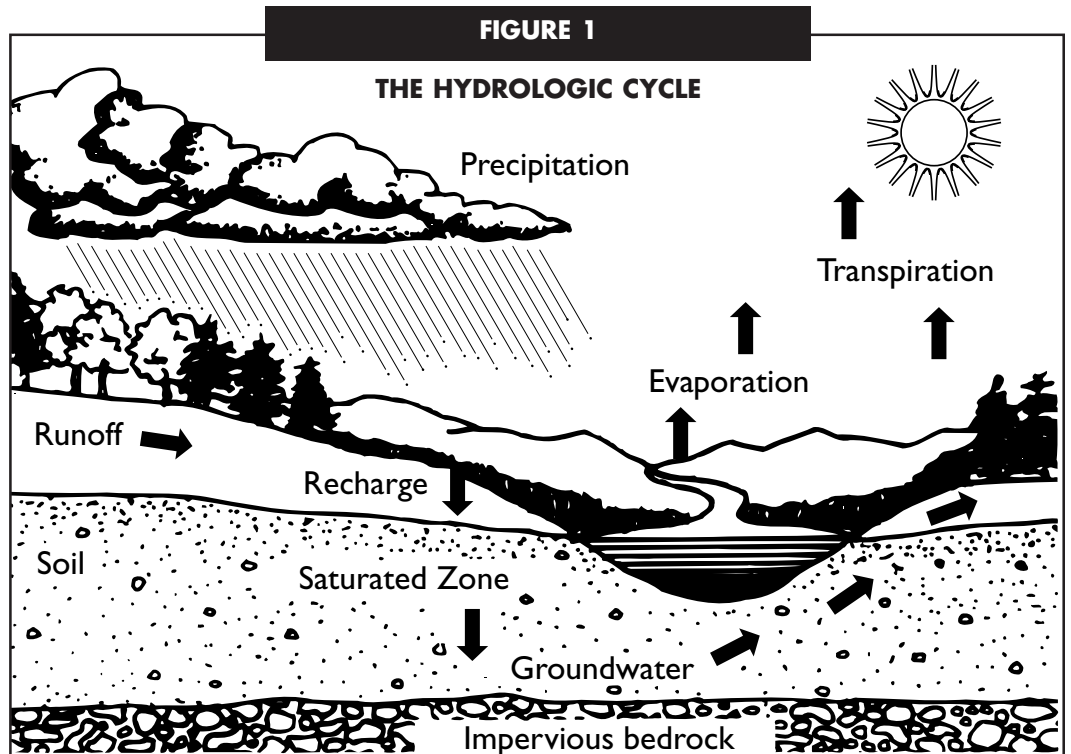



There are three basic systems for storing liquid manure: formed tanks, earthen basins, and lagoons. The type of storage affects the manure volume, the nutrient concentration, and ultimately, the land application rate of the manure. Each system has its own set of construction and management requirements.

SYSTEM DESCRIPTIONS

Formed tanks

Formed tanks, or pits, are used to conserve nutrients if the producer has adequate land to use the manure as crop fertilizer. Estimated nitrogen (N) losses from pits are typically about 30 percent, leaving 70 percent of the excreted N for use by the crops. Formed tanks normally contain 50 to 80 pounds of nitrogen per 1,000 gallons of manure. The concentration depends on the species, the part of the operation the tank serves (farrowing, nursery, finishing), and other management and equipment considerations. For example, swine finishing operations that use wet/dry feeders normally have 30 percent less manure volume and the manure is 30 percent more concentrated than identical operations with dry feeders and nipple waterers.

Compared with lagoons, the nutrient content of manure from formed pits is highly concentrated because little, if any, dilution water is added. Formed pits are too costly for storing dilute forms of manure that require large amounts of fresh water.

Earthen manure storage

Earthen basins are less expensive to construct than formed structures. They are lined with clay or plastic rather than concrete or steel. All earthen basins are constructed outside. Earthen basins have sloping sides rather than vertical sides. Like formed tanks, earthen basins are used with pull-plug gutters and scrapers. Although they

receive no extra dilution water, they do collect some extra rain water due to their sloping sides.

Earthen basins also conserve nutrients, although nitrogen volatilization to the air and dilution water off the sidewalls slightly reduce nutrient concentrations. In Iowa, estimates of N, P₂O₅, and K₂O are 32-22-20 lbs./1,000 gals. Land application rates will be higher than from formed tanks, but still low when compared to lagoons.

While earthen basins are a lower cost storage method, they are thought to be more likely to leak than concrete or steel formed pits. To be environmentally safe, earthen basins must be built correctly and managed properly. IDNR specifies construction requirements regarding factors such as soil type, excavation, and freeboard. Earthen basins must have 2 feet of freeboard.

Because compacted earth is used to seal them, extra care is necessary during agitation and pumpout to avoid eroding holes in the sides or bottom. They're also subject to burrowing rodents and should be checked frequently to prevent problems.

Lagoons

Lagoons are large earthen structures designed to partially treat manure as well as store it. Microbes digest the volatile solids, turning them into liquid and gaseous fractions. Lagoons must receive large quantities of dilution water for the microbes to thrive and grow. Therefore lagoons are typically seven to 10 times larger than formed tanks or earthen basins. Although they provide some treatment, it is not sufficient to allow discharge of the lagoon liquid.

Lagoons can be either aerobic (containing dissolved oxygen in the liquid) or anaerobic (no dissolved oxygen). Agricultural operations almost always use anaerobic lagoons (no oxygen). They are much smaller than aerobic

storage

lagoons, they cost less, and they require less management.

Lagoon systems essentially dispose of nutrients to the air and to the lagoon floor. About 70 percent of the nitrogen from the animals is volatilized to the air, while phosphorus is settled out with solids. Unless the lagoon is vigorously agitated, the phosphorus stays on the bottom as sludge. Producers who don't have adequate land for nutrient application use lagoons to minimize the acreage needed. Lagoons also are used for flush or recharge manure handling systems because they can provide a source of relatively high quality liquid to recycle to the animal houses. These systems are used to improve air quality in buildings.

Lagoon nutrient concentrations are typically one-tenth of pit nutrient concentrations. In Iowa, lagoon estimates of N, P₂O₅, and K₂O are 4-3-4 lbs./1,000 gals.

DRY MANURE STORAGE

Dry manure storage has the potential to pollute ground water. It is important to maintain a minimum of 1 foot of freeboard above the liquid level. Do not pump earth storage structures dry. Leave a small amount of liquid in the bottom to prevent the compacted soil liner from drying out and cracking.

MANAGEMENT REQUIREMENTS

Good management must be continuous for all storage facilities. Management of earthen basins and lagoons includes erosion control on both inside and outside walls. Establish good vegetative cover both on the outside berm and on the inside down to the waterline. Do not use deep rooted vegetation that will create macropores. Fix any small gullies that develop. Rip-rap at the waterline of lagoons is desirable. Manage pumps and agitators to avoid erode holes in the bottom or sides.

Install a depth gauge to show liquid level in the structure. It should be marked at the maximum allowable liquid elevation (where pumpout MUST occur). Read and record the level frequently and regularly. Storage structures should be checked at least once a week; once a

day is better. It is especially important to record the readings if more than one person checks the liquid level. Your first indication of a leaking storage structures may be a decline in the liquid level. Regularly inspect toe drains and tile flows for any off color, odor, foaming, etc. and that pipes are open.

Freeboard should never have stored liquid. A properly maintained freeboard will prevent storage pits and lagoons from overtopping and overflowing, even during heavy rainfall events. Keep freeboards clear by pumping pits at the proper time.

Keep at least a foot of airspace between the slats and the liquid in inside pits. Additional airspace may be needed if pit ventilation is used. Use adequate agitation to minimize solids buildup. Systems using wet/dry feeders and hanging waterers may result in thicker manure, requiring additional water at pumpout time to help with agitation.

Do not pump earthen storage structures dry. Leave a small amount of liquid in the bottom to prevent the compacted soil liner from drying out and cracking.

Monitor pumping at all times. Several releases have occurred from unattended pumping equipment. Plug nearby tile intakes during pumpout. Pumps should have lockouts and safety switches to automatically shut down if pressure changes (if a pipe breaks, pressure will drop; if a plug occurs, pressure will rise). Lockouts also prevent unauthorized people from starting equipment. Keep needles, AI straws, bones, plastic gloves, and other "stuff" out of the storage basin, lagoon, or pit. They can and do interfere with pumps and valves.

storage

STORAGE CAPACITY CALCULATIONS

You should be able to calculate the amount of manure in your storage facility whether it's square, round, or earthen. The following three equations provide simple methods to calculate it. The tables at the end of this chapter provide the same information for the specified sizes. If you have different dimensions or depths than those shown in the tables, you can interpolate between the tables.

Rectangular pits

The equation is

Gallons =
length x width x depth x 7.5
(The 7.5 converts from cubic feet to gallons.)

Example:

You have a 40 x 200 finishing pit, 9 feet deep. You are able to remove 7 feet (all but the bottom foot, plus a foot of freeboard).

Manure volume, gallons =
 $200 \times 40 \times 7 \times 7.5 = 420,000$ gallons
(See Tables 1-3, storage & handling pages 7 and 8 for rectangular pit capacities.)

Round pits

The equation is

Gallons =
diameter x diameter x depth x 0.78 x 7.5
(The 7.5 converts from cubic feet to gallons.)

Example:

You have a 100-foot diameter finishing pit, 10 feet deep. You are able to remove 8 feet (all but the bottom foot, plus a foot of freeboard).

Manure volume, gallons =
 $100 \times 100 \times 8 \times 0.78 \times 7.5 = 468,000$ gallons
(See Table 4, storage & handling page 8 for round tank capacities.)

Earthen basins

The equation for earthen basins is more complicated. We will assume that the sideslopes

are 3:1. The procedure is to calculate the surface area at the waterline before pumpout, add the surface area at the waterline after pumpout, divide by 2 to get the average surface area, then multiply by the depth of manure removal.

To get the dimensions of the surface area after pumpout, take 2 times the sideslope, multiply it by the depth, and subtract it from the full top dimension. Then multiply by 7.5 to convert from cubic feet to gallons.

The equation is

Gallons =
[(top length x top width) + (top length - 6 x depth) x (top width - 6 x depth)] x
 $1/2 \times \text{depth} \times 7.5$

Example:

You have an earthen basin measuring 100 x 300 feet at the waterline, and you want to pump out 10 feet.

Volume calculation:

Surface area before pumping =
 $100 \times 300 = 30,000$ sq. ft.

Surface area after pumping =
[100 - (6 x 10)] x [300 - (6 x 10)] =
 $40 \times 240 = 9600$ sq. ft.

Average surface area =
 $(30,000 + 9600) \times 1/2 = 19,800$ sq. ft.

Volume =
 $19,800 \times 10 \times 7.5 = 1,485,000$ gallons
(See Tables 5-8, storage & handling pages 9 and 10 for earthen basin capacities.)

SUMMARY OF KEY POINTS

- There are three basic types of liquid manure storage systems: formed tanks or pits – can be inside or outside buildings, round or rectangular; earthen basins — similar to formed pits but made of earth; and lagoons – constructed of earth, with much dilution water added.
- Pits and basins are designed for *storage only*. Lagoons are designed to *store* and

storage

treat manure. Lagoon liquid is still not clean enough to release.

impermeable soil, and protected from upslope runoff. Releases from confinement units are prohibited by law, regardless of manure type—liquid or dry.

- Nutrient concentrations in manure are highest in formed pits, less concentrated in earthen basins, and very low in anaerobic lagoons, but all do contain nutrients.
- During construction of any earthen storage it is **EXTREMELY** important to remove any tile lines within 50 feet of the toe of the berm.
- Add plenty of dilution water to avoid overloading lagoons.
- Pits and basins are nutrient-conserving systems. Lagoons are nutrient-wasting systems.
- Properly operated lagoon nutrient concentrations are typically about one-tenth those of pits. Pit nutrients are typically 50-42-30 of N-P₂O₅-K₂O. Lagoon nutrients are typically 4-3-4.
- Outdoor formed storages are required to have at least one foot of freeboard.
- Earthen storages are required to have at least two feet of freeboard.
- The two factors for safe manure storage are good construction and good management.
- Manure volumes can be calculated from the equations at the end of the chapter.
- To convert from cubic feet to gallons, multiply by 7.5.
- Never leave operating pumps, lines, or other equipment unattended.
- Operate pumps in earthen storages carefully to avoid erosion on the sides or bottom.
- Dry manure should be stored under roof whenever possible.
- Dry manure stored outdoors should be well away from streams and waterways, on

storage

storage

TABLE 1

RECTANGULAR PIT CAPACITY GALLONS — 6 FEET OF LIQUID

LENGTH, FT.	WIDTH, FT.								
	20	30	40	50	60	70	80	90	100
40	36,000	54,000	72,000	90,000	108,000	126,000	144,000	162,000	180,000
60	54,000	81,000	108,000	135,000	162,000	189,000	216,000	243,000	270,000
80	72,000	108,000	144,000	180,000	216,000	252,000	288,000	324,000	360,000
100	90,000	135,000	180,000	225,000	270,000	315,000	360,000	405,000	450,000
120	108,000	162,000	216,000	270,000	324,000	378,000	432,000	486,000	540,000
140	126,000	189,000	252,000	315,000	378,000	441,000	504,000	567,000	630,000
160	144,000	216,000	288,000	360,000	432,000	504,000	576,000	648,000	720,000
180	162,000	243,000	324,000	405,000	486,000	567,000	648,000	729,000	810,000
200	180,000	270,000	360,000	450,000	540,000	630,000	720,000	810,000	900,000
220	198,000	297,000	396,000	495,000	594,000	693,000	792,000	891,000	990,000
240	216,000	324,000	432,000	540,000	648,000	756,000	864,000	972,000	1,080,000
260	234,000	351,000	468,000	585,000	702,000	819,000	936,000	1,053,000	1,170,000
280	252,000	378,000	504,000	630,000	756,000	882,000	1,008,000	1,134,000	1,260,000
300	270,000	405,000	540,000	675,000	810,000	945,000	1,080,000	1,215,000	1,350,000
320	288,000	432,000	576,000	720,000	864,000	1,008,000	1,152,000	1,296,000	1,440,000
340	306,000	459,000	612,000	765,000	918,000	1,071,000	1,224,000	1,377,000	1,530,000
360	324,000	486,000	648,000	810,000	972,000	1,134,000	1,296,000	1,458,000	1,620,000
380	342,000	513,000	684,000	855,000	1,026,000	1,197,000	1,368,000	1,539,000	1,710,000
400	360,000	540,000	720,000	900,000	1,080,000	1,260,000	1,440,000	1,620,000	1,800,000

TABLE 2

RECTANGULAR PIT CAPACITY GALLONS — 8 FEET OF LIQUID

LENGTH, FT.	WIDTH, FT.								
	20	30	40	50	60	70	80	90	100
40	48,000	72,000	96,000	120,000	144,000	168,000	192,000	216,000	240,000
60	72,000	108,000	144,000	180,000	216,000	252,000	288,000	324,000	360,000
80	96,000	144,000	192,000	240,000	288,000	336,000	384,000	432,000	480,000
100	120,000	180,000	240,000	300,000	360,000	420,000	480,000	540,000	600,000
120	144,000	216,000	288,000	360,000	432,000	504,000	576,000	648,000	720,000
140	168,000	252,000	336,000	420,000	504,000	588,000	672,000	756,000	840,000
160	192,000	288,000	384,000	480,000	576,000	672,000	768,000	864,000	960,000
180	216,000	324,000	432,000	540,000	648,000	756,000	864,000	972,000	1,080,000
200	240,000	360,000	480,000	600,000	720,000	840,000	960,000	1,080,000	1,200,000
220	264,000	396,000	528,000	660,000	792,000	924,000	1,056,000	1,188,000	1,320,000
240	288,000	432,000	576,000	720,000	864,000	1,008,000	1,152,000	1,296,000	1,440,000
260	312,000	468,000	624,000	780,000	936,000	1,092,000	1,248,000	1,404,000	1,560,000
280	336,000	504,000	672,000	840,000	1,008,000	1,176,000	1,344,000	1,512,000	1,680,000
300	360,000	540,000	720,000	900,000	1,080,000	1,260,000	1,440,000	1,620,000	1,800,000
320	384,000	576,000	768,000	960,000	1,152,000	1,344,000	1,536,000	1,728,000	1,920,000
340	408,000	612,000	816,000	1,020,000	1,224,000	1,428,000	1,632,000	1,836,000	2,040,000
360	432,000	648,000	864,000	1,080,000	1,296,000	1,512,000	1,728,000	1,944,000	2,160,000
380	456,000	684,000	912,000	1,140,000	1,368,000	1,596,000	1,824,000	2,052,000	2,280,000
400	480,000	720,000	960,000	1,200,000	1,440,000	1,680,000	1,920,000	2,160,000	2,400,000

storage

TABLE 3

RECTANGULAR PIT CAPACITY GALLONS — 10 FEET OF LIQUID

LENGTH, FT.	WIDTH, FT.								
	20	30	40	50	60	70	80	90	100
40	60,000	90,000	120,000	150,000	180,000	210,000	240,000	270,000	300,000
60	90,000	135,000	180,000	225,000	270,000	315,000	360,000	405,000	450,000
80	120,000	180,000	240,000	300,000	360,000	420,000	480,000	540,000	600,000
100	150,000	225,000	300,000	375,000	450,000	525,000	600,000	675,000	750,000
120	180,000	270,000	360,000	450,000	540,000	630,000	720,000	810,000	900,000
140	210,000	315,000	420,000	525,000	630,000	735,000	840,000	945,000	1,050,000
160	240,000	360,000	480,000	600,000	720,000	840,000	960,000	1,080,000	1,200,000
180	270,000	405,000	540,000	675,000	810,000	945,000	1,080,000	1,215,000	1,350,000
200	300,000	450,000	600,000	750,000	900,000	1,050,000	1,200,000	1,350,000	1,500,000
220	330,000	495,000	660,000	825,000	990,000	1,155,000	1,320,000	1,485,000	1,650,000
240	360,000	540,000	720,000	900,000	1,080,000	1,260,000	1,440,000	1,620,000	1,800,000
260	390,000	585,000	780,000	975,000	1,170,000	1,365,000	1,560,000	1,755,000	1,950,000
280	420,000	630,000	840,000	1,050,000	1,260,000	1,470,000	1,680,000	1,890,000	2,100,000
300	450,000	675,000	900,000	1,125,000	1,350,000	1,575,000	1,800,000	2,025,000	2,250,000
320	480,000	720,000	960,000	1,200,000	1,440,000	1,680,000	1,920,000	2,160,000	2,400,000
340	510,000	765,000	1,020,000	1,275,000	1,530,000	1,785,000	2,040,000	2,295,000	2,550,000
360	540,000	810,000	1,080,000	1,350,000	1,620,000	1,890,000	2,160,000	2,430,000	2,700,000
380	570,000	855,000	1,140,000	1,425,000	1,710,000	1,995,000	2,280,000	2,565,000	2,850,000
400	600,000	900,000	1,200,000	1,500,000	1,800,000	2,100,000	2,400,000	2,700,000	3,000,000

TABLE 4

ROUND PIT CAPACITY GALLONS — VARIOUS DEPTHS

DIAMETER	DEPTH, FT.									
	4	5	6	7	8	9	10	11	12	
40	37,696	47,120	56,544	65,968	75,392	84,816	94,240	103,664	113,088	
50	58,900	73,625	88,350	103,075	117,800	132,525	147,250	161,975	176,700	
60	84,816	106,020	127,224	148,428	169,632	190,836	212,040	233,244	254,448	
70	115,444	144,305	173,166	202,027	230,888	259,749	288,610	317,471	346,332	
80	150,784	188,480	226,176	263,872	301,568	339,264	376,960	414,656	452,352	
90	190,836	238,545	286,254	333,963	381,672	429,381	477,090	524,799	572,508	
100	235,600	294,500	353,400	412,300	471,200	530,100	589,000	647,900	706,800	
110	285,076	356,345	427,614	498,883	570,152	641,421	712,690	783,959	855,228	
120	339,264	424,080	508,896	593,712	678,528	763,344	848,160	932,976	1,017,792	
130	398,164	497,705	597,246	696,787	796,328	895,869	995,410	1,094,951	1,194,492	
140	461,776	577,220	692,664	808,108	923,552	1,038,996	1,154,440	1,269,884	1,385,328	
150	530,100	662,625	795,150	927,675	1,060,200	1,192,725	1,325,250	1,457,775	1,590,300	
160	603,136	753,920	904,704	1,055,488	1,206,272	1,357,056	1,507,840	1,658,624	1,809,408	
170	680,884	851,105	1,021,326	1,191,547	1,361,768	1,531,989	1,702,210	1,872,431	2,042,652	
180	763,344	954,180	1,145,016	1,335,852	1,526,688	1,717,524	1,908,360	2,099,196	2,290,032	
190	850,516	1,063,145	1,275,774	1,488,403	1,701,032	1,913,661	2,126,290	2,338,919	2,551,548	
200	942,400	1,178,000	1,413,600	1,649,200	1,884,800	2,120,400	2,356,000	2,591,600	2,827,200	
210	1,038,996	1,298,745	1,558,494	1,818,243	2,077,992	2,337,741	2,597,490	2,857,239	3,116,988	
220	1,140,304	1,425,380	1,710,456	1,995,532	2,280,608	2,565,684	2,850,760	3,135,836	3,420,912	
230	1,246,324	1,557,905	1,869,486	2,181,067	2,492,648	2,804,229	3,115,810	3,427,391	3,738,972	
240	1,357,056	1,696,320	2,035,584	2,374,848	2,714,112	3,053,376	3,392,640	3,731,904	4,071,168	

storage

TABLE 5

EARTHEN BASINS CAPACITY — PUMPOUT DEPTH = 6 FEET

Assumes 3:1 sideslopes (horizontal:vertical)

LENGTH, FT.	WIDTH, FT.										
	50	75	100	125	150	175	200	225	250	275	300
50	60,660	96,660	132,660	168,660	204,660	240,660	276,660	312,660	348,660	384,660	420,660
75	96,660	160,785	224,910	289,035	353,160	417,285	481,410	545,535	609,660	673,785	737,910
100	132,660	224,910	317,160	409,410	501,660	593,910	686,160	778,410	870,660	962,910	1,055,160
125	168,660	289,035	409,410	529,785	650,160	770,535	890,910	1,011,285	1,131,660	1,252,035	1,372,410
150	204,660	353,160	501,660	650,160	798,660	947,160	1,095,660	1,244,160	1,392,660	1,541,160	1,689,660
175	240,660	417,285	593,910	770,535	947,160	1,123,785	1,300,410	1,477,035	1,653,660	1,830,285	2,006,910
200	276,660	481,410	686,160	890,910	1,095,660	1,300,410	1,505,160	1,709,910	1,914,660	2,119,410	2,324,160
225	312,660	545,535	778,410	1,011,285	1,244,160	1,477,035	1,709,910	1,942,785	2,175,660	2,408,535	2,641,410
250	348,660	609,660	870,660	1,131,660	1,392,660	1,653,660	1,914,660	2,175,660	2,436,660	2,697,660	2,958,660
275	384,660	673,785	962,910	1,252,035	1,541,160	1,830,285	2,119,410	2,408,535	2,697,660	2,986,785	3,275,910
300	420,660	737,910	1,055,160	1,372,410	1,689,660	2,006,910	2,324,160	2,641,410	2,958,660	3,275,910	3,593,160
325	456,660	802,035	1,147,410	1,492,785	1,838,160	2,183,535	2,528,910	2,874,285	3,219,660	3,565,035	3,910,410
350	492,660	866,160	1,239,660	1,613,160	1,986,660	2,360,160	2,733,660	3,107,160	3,480,660	3,854,160	4,227,660
375	528,660	930,285	1,331,910	1,733,535	2,135,160	2,536,785	2,938,410	3,340,030	3,741,660	4,143,285	4,544,910
400	564,660	994,410	1,424,160	1,853,910	2,283,660	2,713,410	3,143,160	3,572,910	4,002,660	4,432,410	4,862,160
425	600,660	1,058,535	1,516,410	1,974,285	2,432,160	2,890,035	3,347,910	3,805,785	4,263,660	4,721,535	5,179,410
450	636,660	1,122,660	1,608,660	2,094,660	2,580,660	3,066,660	3,552,660	4,038,660	4,524,660	5,010,660	5,496,660
475	672,660	1,186,785	1,700,910	2,215,035	2,729,160	3,243,285	3,757,410	4,271,535	4,785,660	5,299,785	5,813,910
500	708,660	1,250,910	1,793,160	2,335,410	2,877,660	3,419,910	3,962,160	4,504,410	5,046,660	5,588,910	6,131,160

TABLE 6

EARTHEN BASINS CAPACITY — PUMPOUT DEPTH = 8 FEET

Assumes 3:1 sideslopes (horizontal:vertical)

LENGTH, FT.	WIDTH, FT.										
	50	75	100	125	150	175	200	225	250	275	300
50	75,120	114,120	153,120	192,120	231,120	270,120	309,120	348,120	387,120	426,120	465,120
75	114,120	190,620	267,120	343,620	420,120	496,620	573,120	649,620	726,120	802,620	879,120
100	153,120	267,120	381,120	495,120	609,120	723,120	837,120	951,120	1,065,120	1,179,120	1,293,120
125	192,120	343,620	495,120	646,620	798,120	949,620	1,101,120	1,252,620	1,404,120	1,555,620	1,707,120
150	231,120	420,120	609,120	798,120	987,120	1,176,120	1,365,120	1,554,120	1,743,120	1,932,120	2,121,120
175	270,120	496,620	723,120	949,620	1,176,120	1,402,620	1,629,120	1,855,620	2,082,120	2,308,620	2,535,120
200	309,120	573,120	837,120	1,101,120	1,365,120	1,629,120	1,893,120	2,157,120	2,421,120	2,685,120	2,949,120
225	348,120	649,620	951,120	1,252,620	1,554,120	1,855,620	2,157,120	2,458,620	2,760,120	3,061,620	3,363,120
250	387,120	726,120	1,065,120	1,404,120	1,743,120	2,082,120	2,421,120	2,760,120	3,099,120	3,438,120	3,777,120
275	426,120	802,620	1,179,120	1,555,620	1,932,120	2,308,620	2,685,120	3,061,620	3,438,120	3,814,620	4,191,120
300	465,120	879,120	1,293,120	1,707,120	2,121,120	2,535,120	2,949,120	3,363,120	3,777,120	4,191,120	4,605,120
325	504,120	955,620	1,407,120	1,858,620	2,310,120	2,761,620	3,213,120	3,664,620	4,116,120	4,567,620	5,019,120
350	543,120	1,032,120	1,521,120	2,010,120	2,499,120	2,988,120	3,477,120	3,966,120	4,455,120	4,944,120	5,433,120
375	582,120	1,108,620	1,635,120	2,161,620	2,688,120	3,214,620	3,741,120	4,267,620	4,794,120	5,320,620	5,847,120
400	621,120	1,185,120	1,749,120	2,313,120	2,877,120	3,441,120	4,005,120	4,569,120	5,133,120	5,697,120	6,261,120
425	660,120	1,261,620	1,863,120	2,464,620	3,066,120	3,667,620	4,269,120	4,870,620	5,472,120	6,073,620	6,675,120
450	699,120	1,338,120	1,977,120	2,616,120	3,255,120	3,894,120	4,533,120	5,172,120	5,811,120	6,450,120	7,089,120
475	738,120	1,414,620	2,091,120	2,767,620	3,444,120	4,120,620	4,797,120	5,473,620	6,150,120	6,826,620	7,503,120

storage

TABLE 7

EARTHEN BASINS CAPACITY GALLONS — PUMPOUT DEPTH = 10 FEET
Assumes 3:1 sideslopes (horizontal:vertical)

LENGTH, FT.	WIDTH, FT.										
	50	75	100	125	150	175	200	225	250	275	300
50	97,500	135,000	172,500	210,000	247,500	285,000	322,500	360,000	397,500	435,000	472,500
75	135,000	219,375	303,750	388,125	472,500	556,875	641,250	725,625	810,000	894,375	978,750
100	172,500	303,750	435,000	566,250	697,500	828,750	960,000	1,091,250	1,222,500	1,353,750	1,485,000
125	210,000	388,125	566,250	744,375	922,500	1,100,625	1,278,750	1,456,875	1,635,000	1,813,125	1,991,250
150	247,500	472,500	697,500	922,500	1,147,500	1,372,500	1,597,500	1,822,500	2,047,500	2,272,500	2,497,500
175	285,000	556,875	828,750	1,100,625	1,372,500	1,644,375	1,916,250	2,188,125	2,460,000	2,731,875	3,003,750
200	322,500	641,250	960,000	1,278,750	1,597,500	1,916,250	2,235,000	2,553,750	2,872,500	3,191,250	3,510,000
225	360,000	725,625	1,091,250	1,456,875	1,822,500	2,188,125	2,553,750	2,919,375	3,285,000	3,650,625	4,016,250
250	397,500	810,000	1,222,500	1,635,000	2,047,500	2,460,000	2,872,500	3,285,000	3,697,500	4,110,000	4,522,500
275	435,000	894,375	1,353,750	1,813,125	2,272,500	2,731,875	3,191,250	3,650,625	4,110,000	4,569,375	5,028,750
300	472,500	978,750	1,485,000	1,991,250	2,497,500	3,003,750	3,510,000	4,016,250	4,522,500	5,028,750	5,535,000
325	510,000	1,063,125	1,616,250	2,169,375	2,722,500	3,275,625	3,828,750	4,381,875	4,935,000	5,488,125	6,041,250
350	547,500	1,147,500	1,747,500	2,347,500	2,947,500	3,547,500	4,147,500	4,747,500	5,347,500	5,947,500	6,547,500
375	585,000	1,231,875	1,878,750	2,525,625	3,172,500	3,819,375	4,466,250	5,113,125	5,760,000	6,406,875	7,053,750
400	622,500	1,316,250	2,010,000	2,703,750	3,397,500	4,091,250	4,785,000	5,478,750	6,172,500	6,866,250	7,560,000
425	660,000	1,400,625	2,141,250	2,881,875	3,622,500	4,363,125	5,103,750	5,844,375	6,585,000	7,325,625	8,066,250
450	697,500	1,485,000	2,272,500	3,060,000	3,847,500	4,635,000	5,422,500	6,210,000	6,997,500	7,785,000	8,572,500

TABLE 8

EARTHEN BASINS CAPACITY GALLONS — PUMPOUT DEPTH = 12 FEET
Assumes 3:1 sideslopes (horizontal:vertical)

LENGTH, FT.	WIDTH, FT.										
	50	75	100	125	150	175	200	225	250	275	300
50	134,280	165,780	197,280	228,780	260,280	291,780	323,280	354,780	386,280	417,780	449,280
75	165,780	253,530	341,280	429,030	516,780	604,530	692,280	780,030	867,780	955,530	1,043,280
100	197,280	341,280	485,280	629,280	773,280	917,280	1,061,280	1,205,280	1,349,280	1,493,280	1,637,280
125	228,780	429,030	629,280	829,530	1,029,780	1,230,030	1,430,280	1,630,530	1,830,780	2,031,030	2,231,280
150	260,280	516,780	773,280	1,029,780	1,286,280	1,542,780	1,799,280	2,055,780	2,312,280	2,568,780	2,825,280
175	291,780	604,530	917,280	1,230,030	1,542,780	1,855,530	2,168,280	2,481,030	2,793,780	3,106,530	3,419,280
200	323,280	692,280	1,061,280	1,430,280	1,799,280	2,168,280	2,537,280	2,906,280	3,275,280	3,644,280	4,013,280
225	354,780	780,030	1,205,280	1,630,530	2,055,780	2,481,030	2,906,280	3,331,530	3,756,780	4,182,030	4,607,280
250	386,280	867,780	1,349,280	1,830,780	2,312,280	2,793,780	3,275,280	3,756,780	4,238,280	4,719,780	5,201,280
275	417,780	955,530	1,493,280	2,031,030	2,568,780	3,106,530	3,644,280	4,182,030	4,719,780	5,257,530	5,795,280
300	449,280	1,043,280	1,637,280	2,231,280	2,825,280	3,419,280	4,013,280	4,607,280	5,201,280	5,795,280	6,389,280
325	480,780	1,131,030	1,781,280	2,431,530	3,081,780	3,732,030	4,382,280	5,032,530	5,682,780	6,333,030	6,983,280
350	512,280	1,218,780	1,925,280	2,631,780	3,338,280	4,044,780	4,751,280	5,457,780	6,164,280	6,870,780	7,577,280
375	543,780	1,306,530	2,069,280	2,832,030	3,594,780	4,357,530	5,120,280	5,883,030	6,645,780	7,408,530	8,171,280
400	575,280	1,394,280	2,213,280	3,032,280	3,851,280	4,670,280	5,489,280	6,308,280	7,127,280	7,946,280	8,765,280
425	606,780	1,482,030	2,357,280	3,232,530	4,107,780	4,983,030	5,858,280	6,733,530	7,608,780	8,484,030	9,359,280
450	638,280	1,569,780	2,501,280	3,432,780	4,364,280	5,295,780	6,227,280	7,158,780	8,090,280	9,021,780	9,953,280
475	669,780	1,657,530	2,645,280	3,633,030	4,620,780	5,608,530	6,596,280	7,584,030	8,571,780	9,559,530	10,547,280

managing manure nutrients for crop production



Each year Iowa livestock produce enough nitrogen (N), phosphorus (P), and potassium (K) to supply 13 pounds of N, 13 pounds of P_2O_5 , and 21 pounds of K_2O for every acre of corn (see Table 1, nutrient management page 6). The manure is routinely applied to fields surrounding the livestock operations. However, it is important that manure be handled, stored, and applied to fields efficiently and carefully to avoid harming the environment.

Nutrients in animal manure should be managed with the same care as commercial fertilizer. To do so it is necessary to determine:

- total amount of nutrients in the manure,
- availability of the nutrients to the crop, and
- amount of nutrients required to optimize crop yields.

DETERMINING NUTRIENT CONTENT

Three methods can be used to determine the total amount of nutrients in animal manure.

1. The best method is to have a sample of the manure chemically analyzed and measure the volume of the manure storage unit. This eliminates the need to make assumptions about storage losses of nutrients. However, it does require a representative sample of the manure and storage volume calculations.

(See ISU Extension publication PM 1558 for information on how to sample.)

Example:

a. 125,000 birds produce 1,313 tons of manure annually. The chemical analysis of the manure is 40 pounds N per ton, 40 pounds P_2O_5 per ton, and 25 pounds K_2O per ton. The total amount of nutrients in the storage is:

$$\begin{aligned} \text{N:} & 1,313 \times 40 \text{ lbs.} = 52,520 \text{ lbs. N} \\ \text{P}_2\text{O}_5: & 1,313 \times 40 \text{ lbs.} = 52,520 \text{ lbs. P}_2\text{O}_5 \\ \text{K}_2\text{O:} & 1,313 \times 25 \text{ lbs.} = 32,825 \text{ lbs. K}_2\text{O} \end{aligned}$$

b. You have 500,000 gallons of manure and the chemical analysis is 50 pounds N, 35 pounds P_2O_5 , and 30 pounds K_2O per 1,000 gallons the total amount of nutrients in the storage is:

$$\text{N: } 50 \text{ lbs.} \times 500 = 25,000 \text{ lbs. N}$$

$$\begin{aligned} \text{P}_2\text{O}_5: & 35 \text{ lbs.} \times 500 = 17,500 \text{ lbs. P}_2\text{O}_5 \\ \text{K}_2\text{O:} & 30 \text{ lbs.} \times 500 = 15,000 \text{ lbs. K}_2\text{O} \end{aligned}$$

2. The second method calculates storage capacities and multiplies that by the average estimated nutrient content (see Table 2, page 7). This table is a good reference to begin developing application rates. However, both volumes and nutrient concentrations can vary significantly among storage facilities and livestock operations.

3. The third method calculates the average amount of manure produced per day by the animals, multiplies that by the number of animals at the site, and assumes standard storage and handling losses. Table 3 (see page 8) lists annual N, P_2O_5 , and K_2O production after estimated losses are deducted for each confinement space for various livestock species and manure handling systems. This method is a good one for planning the number of acres that will be needed for manure application for new facilities or for expansion of existing ones.

CROP AVAILABILITY

Animal manure contains all the nutrients essential for plant growth. The form of plant nutrients in manure varies between the urine and fecal fractions, depending on nutrients and the species.

For example, about 48 percent of the N in cattle manure is contained in the feces and 52 percent in the urine (mostly as urea or uric acid). Virtually all the N in poultry manure is urea or uric acid.

The nutrients also are distributed between inorganic and organic forms within manure. The inorganic forms (primarily ammonia) are readily available for crop use. The nutrients in organic forms (pieces of soybean meal, hair, particles of corn, and complex organic acids) must be converted be used by crops. This conversion, called

managing manure nutrients for crop production

mineralization, is accomplished by microorganisms that live in all soils.

Mineralization rates depend on factors such as soil temperature and moisture, making it difficult to predict how fast this process will occur.

Nitrogen availability

The amount of the total nitrogen available depends on the species and whether the manure is liquid or solid. Recent research suggests that 30 to 40 percent of the total N in dry beef cattle and dairy manure is available for crops the year of application with 10 percent available the second year and 5 percent the third year. All of the N in swine manure from liquid handling systems is available the first year of application and 65 percent of the total N in poultry manure is available the first year of application. These estimates do not account for potential losses (ammonia volatilization) at the time of application.

Nitrogen in ammonium and urea can be lost into the atmosphere during and after land application (volatilization). If the manure is left on the soil's surface the ammonium and urea will form the gas ammonia. Ammonia moves freely into the atmosphere. You must therefore make adjustments for volatilization losses. The amount of N available after volatilization is the amount left for crops. Suggested adjustment factors from the Iowa Department of Natural Resources (IDNR) are listed in Table 4 (*see page 9*).

Examples:

c. You have solid manure from a dairy operation that contains 12 pounds N, 6 pounds P_2O_5 , and 12 pounds K_2O per ton. The manure will be broadcast onto the land; it will not be incorporated.

$$\begin{aligned} \text{The volatilization correction} &= \\ 12 \text{ lbs. N} \times 0.7 &= 8.4 \text{ lbs. N/ton} \end{aligned}$$

$$\begin{aligned} \text{The amount of N available the year} \\ \text{of application} &= \\ 8.4 \text{ lbs. N} \times 0.35 &= 2.9 \text{ lbs. N/ton} \end{aligned}$$

d. You have liquid swine manure from a farrow-to-finish operation that contains 44 pounds N, 32 pounds P_2O_5 , and 24 pounds K_2O per 1,000 gallons. The manure will be broadcast and

incorporated within 24 hours.

$$\begin{aligned} \text{The volatilization correction} &= \\ 44 \text{ lbs. N} \times 0.95 &= 41.8 \text{ lbs. N/1,000 gallons} \end{aligned}$$

$$\begin{aligned} \text{The amount of N available the year} \\ \text{of application} &= \\ 41.8 \text{ lbs. N/1000 gallons} \end{aligned}$$

(Remember that all the N in liquid swine manure is available to plants the first year.)

e. You have poultry manure from a caged layer operation that contains 35 pounds N, 80 pounds P_2O_5 , and 50 pounds K_2O per ton. The manure will be broadcast and incorporated within 24 hours.

$$\begin{aligned} \text{The volatilization correction} &= \\ 35 \text{ lbs. N} \times 0.95 &= 33.3 \text{ lbs. N/ton} \end{aligned}$$

$$\begin{aligned} \text{The amount of N available the year} \\ \text{of application} &= \\ 33.3 \times 0.65 &= 21.6 \text{ lbs. N/ton} \end{aligned}$$

Phosphorus availability

Phosphorus is present in both inorganic and organic forms. About 60 percent of the total P in manure will be available to crops the year of application but will have little effect on production if the manure is applied to soils that test "high" or "very high." See ISU Extension publication PM 1688, *General Guide for Crop Nutrient Recommendations in Iowa* (\$1 per copy), for a complete list of soil test interpretations. If manure is applied to soils to replace the amount removed in the harvested portion of the crop, assume that all of the P is available.

If your soils test "very low," "low," or "optimum," crop yields likely will be reduced by underapplication of P. If the manure is being applied to these soils, assume that 60 percent of the total P in the manure is available.

Potassium availability

Potassium is present in animal manure as the inorganic ion K^+ . This is the form of K used by plants, so assume that 100 percent of the total K in animal manure is available to plants the year of application.

managing manure nutrients for crop production

NUTRIENT REQUIREMENTS FOR CROP PRODUCTION

Manure application rates can be determined using N, P, or K. There are two methods for determining nitrogen needs.

Method 1 for nitrogen

You can estimate your nitrogen needs by multiplying the proven yield for a given field (or area of a field) by a factor that represents the crop's N requirement. Iowa has three factors for manure supplying nitrogen to corn (*see Figure 1, page 6*). Table 5 (*see page 9*) shows nutrient removal for other crops. Calculate the requirement by taking the nitrogen requirement and reducing it by the amount of N contributed from other sources such as the previous crop, previous manure additions, or starter fertilizers.

The equation is

$N \text{ fertilizer} = (\text{Proven yield} \times N \text{ factor}) - N \text{ credits}$

N credits include:

- 1 pound N equivalent per bushel of soybean up to 50 pounds N per acre
- 10 percent of the N in bedded manure applied the previous year
- alfalfa

Example:

f. You have established that you can grow 150 bushels of corn per acre on a given field in north central Iowa. Last year's soybean crop yielded 60 bushels per acre.

$$N \text{ fertilizer} = (150 \times 1.2) - 50 \text{ lbs. N/acre} \\ = (180) - 50 = 130 \text{ lbs. N/acre}$$

The 1.2 is the N factor for most of Iowa. Even though last year's soybean crop yielded 60 bushels per acre, the maximum N credit for soybeans is 50 pounds per acre.

Method 2 for nitrogen

The other method is a Late Spring Soil Nitrate Test (*see ISU Extension publication PM 1714, Nitrogen Fertilizer Recommendations for Corn in*

Iowa). A 0- to 12-inch soil sample is collected from a field or parts of a field while corn is 6 to 12 inches tall. The soil sample is analyzed for nitrate-nitrogen ($\text{NO}_3\text{-N}$), and nitrogen then is applied according to Table 6 (*see page 10*). If the test indicates less than 20 ppm $\text{NO}_3\text{-N}$ under conditions of normal rainfall and favorable corn prices, nitrogen or manure must be side-dressed to ensure optimum yields. This method cannot be used to determine how much manure to apply in the fall for next year's corn crop. The amount from Method 1, or slightly less, probably is a good estimate.

ALLOCATING MANURE TO FIELDS

Manure can be allocated to supply the N, P, or K requirements of the crop that will be grown. Annual applications may result in a rapid increase in soil test P and K. For instance, in Example a, if the poultry manure is applied to supply 150 pounds of N per acre and incorporated immediately, this also will apply approximately 150 pounds of P_2O_5 per acre and 95 pounds K_2O per acre. A more conservative approach is to apply the manure to supply the P or K needs of the crop either through lower annual rates or less frequent applications. This will not result in increases in soil test P or K; however, it will increase the acreage needed for manure application. Soil testing is the best way to determine the amount of P and K for optimum crop production. Applying manure to supply P or K, then using Method 2 for N (above) usually optimizes both the environmental and economic benefits of manure use.

Manure should be allocated as follows:

- Fields that test very low in P and K and are going to be planted to corn;
- Fields that test low in P and K and will be planted to corn;
- Fields that test very low in P and K and will be planted to soybeans; and
- Fields that test low in P and K and will be planted to soybeans.

managing manure nutrients for crop production

(See Table 7, page 10, for a more complete list of suggested field priorities.)

When selecting fields for manure application consider the nutrient requirements of your crop rotation. For example, in a corn-soybean rotation apply the manure every other year to supply the N requirements of the corn, and the P may meet the requirements for both the corn and the soybeans. This usually is very effective in Iowa and is popular among producers. Also consider the proximity of fields to the manure storage facility and the time required to transport the manure.

SCHEDULING APPLICATION

The time of application influences nutrient availability and potential movement. Fall applications allow more time for organic portions of the manure to mineralize so they are available for plant uptake. However, the increased time for mineralization also allows for more potential nitrogen loss to the environment. Coarse-textured soils are the most likely to leach with fall-applied manure and nitrogen. Manure applied in the spring has the least amount of time for nitrogen loss to occur, but spring application is the most likely to cause soil compaction.

As a general rule, do not apply manure in the fall unless the soil temperature is 50°F to a depth of four inches and cooling. This will slow the mineralization process.

Applying manure to frozen soils increases the potential for environmental contamination. Nitrogen and phosphorus movement into surface water can be significant and nitrogen losses can be high. If manure must be applied to frozen ground, it should be applied on relatively flat land (slopes less than 4 percent and well away from streams and waterways, see IDNR rules on setback distances).

SUMMARY OF KEY POINTS

- Manage the nutrients in animal manure as you would commercial fertilizer.

- Have a representative sample chemically analyzed to determine nutrient content of your manure.
- Adjust the rate of manure application to account for the plant availability of nitrogen and phosphorus.
- Adjust manure rates to account for nitrogen volatilization.
- Base the manure application rate on either nitrogen or phosphorus needs, but do not exceed the N requirement.
- Apply manure to meet the nutrient needs of crop rotations rather than individual crops.
- Allocate manure to fields based on soil tests and the crop to be grown.
- Fall applications of manure should not be made until the soil temperature is 50° F and cooling.

References

Blackmer, A.M., R.D. Voss, and A.P. Mallarino. 1997. Nitrogen fertilizer recommendations for corn in Iowa. PM 1714. Iowa State University Extension. Ames, Iowa

Prepared by Randy Killorn, professor of soil fertility and Jeff Lorimor, assistant professor of agricultural and biosystems engineering.

This publication replaces ISU Extension publications PM 1596a and PM 1599.

managing manure nutrients for crop production

managing manure nutrients for crop production

FIGURE 1

CORN N REQUIREMENTS

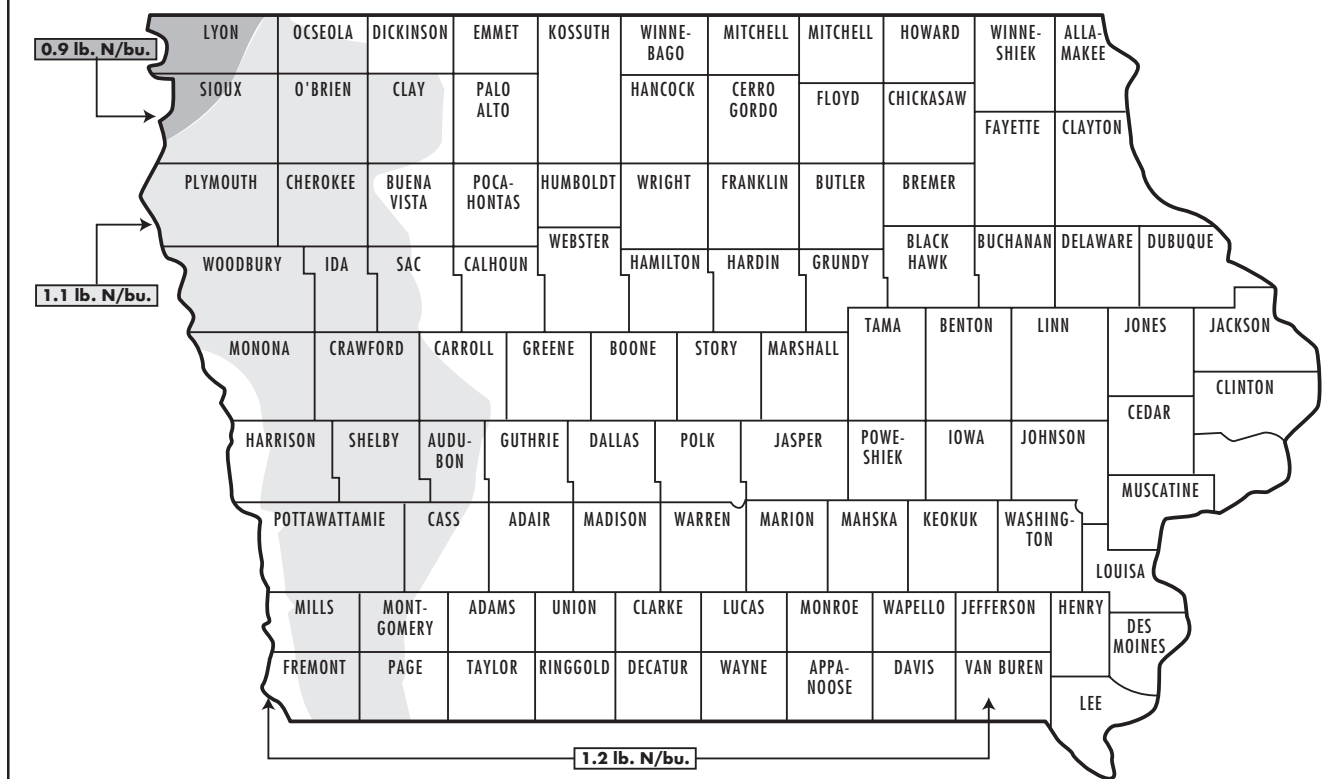

TABLE 1

PLANT AVAILABLE NUTRIENTS EXCRETED BY LIVESTOCK IN IOWA IN 1990

ANIMAL	NUMBER OF ANIMALS ^a x 1,000	-----NUTRIENTS EXCRETED ^b -----			----- AVAILABLE NUTRIENTS ^c -----		
		N lbs./animal year	P ₂ O ₅	K ₂ O	N lbs. (x 1,000)	P ₂ O ₅	K ₂ O
Beef (500 lbs.)	1,347	124	91	106	41,757	42,902	71,391
Dairy (>500 lbs.)	443	180	89	143	19,935	13,799	31,675
Breeding Hogs	1,680	30	23	24	12,600	13,524	20,160
Market Hogs	11,820	30	23	24	88,650	95,151	141,840
Chickens	11,900	0.95	0.68	0.43	2,826	2,832	2,559

^a From 1990 Crop and Livestock Reporting Service.

^b Midwest Planning Service. 1985, Livestock Waste Facilities Handbook (2nd ed.) MWPS-18.

^c Assuming that 50 percent of the nutrients are recoverable and that 50 percent of the N and P₂O₅ and 100 percent of the K₂O is available to

managing manure nutrients for crop production

TABLE 2

NUTRIENTS IN ANIMAL MANURE

MANAGEMENT SYSTEM	N	P ₂ O ₅	K ₂ O	
LIQUID, PIT	--lbs./1,000 gals. --	gals./day		
Swine				
Nursery, 25 lbs.	35	20	20	0.2
Grow-finish, 150 lbs. (wet/dry)	75	54	40	0.84
Grow-finish, 150 lbs. (dry feed)	50	42	30	1.2
Grow-finish, 150 lbs. (earthen)	32	22	20	1.2
Gestation, 400 lbs.	25	25	25	1.6
Sow and litter ^a , 450 lbs.	25	20	15	3.5
Farrow-nursery ^b	27	23	22	2.2
Farrow-finish ^c	44	32	24	9.4
Dairy—confined				
Cows, 1,200 lbs. or more	30	15	25	11.8
Heifers, 900 lbs.	30	15	25	8.8
Calves, 500 lbs.	30	15	25	4.9
Veal calves, 250 lbs.	30	15	25	2.5
Dairy herd ^d	30	15	25	18.5
Beef—confined				
Mature cows, 1,000 lbs.	40	25	35	7.2
Finishing, 900 lbs.	40	25	35	6.5
Feeder calves, 500 lbs.	40	25	35	3.6
Lagoon^e (all animals)				
	4	3	4	See Table 3
OPEN LOT RUNOFF -- lbs./1,000 gals. -- gals./day				
Earthen lots (liquids)				
Beef, 400 sq. ft./hd.	3	1	6	4.9
Dairy, 1,000 sq. ft./hd.	3	1	6	13.5
Swine, 50 sq. ft./hd.	3	1	6	0.7
Concrete lots (liquids)				
Beef, 400 sq. ft./hd.	6	2	7	1.6
Dairy, 1,000 sq. ft./hd.	6	2	7	3.2
Swine, 50 sq. ft./hd.	15	5	10	0.5

MANAGEMENT SYSTEM	N	P ₂ O ₅	K ₂ O	
SOLID MANURE (BEDDED)	----- lbs./T.	----- T./hd./yr.		
Swine—confined				
Nursery, 25 lbs.	14	9	11	0.34
Grow-finish, 150 lbs.	14	9	11	2.05
Gestation, 400 lbs.	14	9	11	2.77
Sow and litter, 450 lbs.	14	9	11	6.16
Farrow-nursery	14	9	11	6.09
Farrow-finish	14	9	11	12.25
Dairy—confined				
Cows, 1,200 lbs. or more	12	6	12	19.93
Heifers, 900 lbs.	12	6	12	14.95
Calves, 500 lbs.	12	6	12	8.3
Veal calves, 250 lbs.	12	6	12	4.15
Dairy herd	12	6	12	32.77
Beef—confined				
Mature cows, 1,000 lbs.	12	6	12	12.23
Finishing, 900 lbs.	12	6	12	11
Feeder calves, 500 lbs.	12	6	12	6.11
Open lot (solids - scraped)				
Beef, 400 sq. ft./hd.	22	16	14	3
Dairy, 1,000 sq. ft./hd.	11	6	11	11.5
Swine, 50 sq. ft./hd.	15	14	9	1.2
				birds
Poultry ----- lbs./T. ----- T./1,000/yr.				
Layer, caged, 4 lbs. ^f	35	80	50	10.5

^a Sow and litter figures are per farrowing crate.

^b Farrow-nursery figures are per sow in the breeding herd and include one farrowing sow, five gestation sows, and nine nursery pig spaces.

^c Farrow-finish figures are per sow in the breeding herd and include one farrowing sow, five gestation sows, nine nursery pigs, and 36 finishing pig spaces.

^d Per productive cow in the herd; includes lactating cow, 330 days; dry cow, 35 days; heifer, 222 days; and calf, 165 days.

^e Weights assumed: beef, 1,000 pounds.; dairy, 1,200 pounds.; swine, 150 pounds.

^f Wet basis at 41 percent moisture.

managing manure nutrients for crop production

TABLE 3

NUTRIENTS EXCRETED BY ANIMALS

MANAGEMENT SYSTEM	N	P ₂ O ₅	K ₂ O	MANAGEMENT SYSTEM	N	P ₂ O ₅	K ₂ O				
LIQUID, PIT	--- lbs./space/yr. --- gals./day			OPEN LOT RUNOFF	--- lbs./space/yr. --- gals./day						
Swine				Earthen lots (liquids)							
Nursery, 25 lbs.	2	1	1	0.2	Beef, 400 sq. ft./hd.	5	2	11	4.9		
Grow-finish, 150 lbs. (wet/dry)	23	17	12	0.84	Dairy, 1,000 sq. ft./hd.	15	5	29	13.5		
Grow-Finish, 150 lbs. (dry feeds)	21	15	11	1.2	Swine, 50 sq. ft./hd.	1	0.3	2	0.7		
Grow-Finish, 150 lbs. (earthen)	14	10	9	1.2	Concrete lots (liquids)						
Gestation, 400 lbs.	14	14	14	1.6	Beef, 400 sq. ft./hd.	3	1	4	1.6		
Sow and litter ^a , 450 lbs.	32	26	19	3.5	Dairy, 1,000 sq. ft./hd.	7	2	8	3.2		
Farrow-nursery ^b	22	18	18	2.2	Swine, 50 sq. ft./hd.	3	1	2	0.5		
Farrow-finish ^c	150	109	82	9.4	SOLID MANURE (BEDDED) --- lbs./space/yr. --- T./hd./yr.						
Dairy—confined				Swine—confined							
Cows, 1,200 lbs. or more	129	65	108	11.8	Nursery, 25 lbs.	5	3	4	0.34		
Heifers, 900 lbs.	97	48	81	8.8	Grow-finish, 150 lbs.	29	18	23	2.05		
Calves, 500 lbs.	54	27	45	4.9	Gestation, 400 lbs.	39	25	30	2.77		
Veal calves, 250 lbs.	27	13	22	2.5	Sow and litter, 450 lbs.	86	55	68	6.16		
Dairy herd ^d	203	101	169	18.5	Farrow-nursery	85	55	67	6.09		
Beef—confined				Farrow-finish				172	110	135	12.25
Mature cows, 1,000 lbs.	105	66	92	7.2	Dairy—confined						
Finishing, 900 lbs.	95	59	83	6.5	Cows, 1,200 lbs. or more	239	120	239	19.93		
Feeder calves, 500 lbs.	53	33	46	3.6	Heifers, 900 lbs.	179	90	179	14.95		
LAGOON^e				--- lbs./space/yr. --- gals./day							
Swine				Beef—confined							
Nursery, 25 lbs.	1	0.7	1	0.7	Mature cows, 1,000 lbs.	147	73	147	12.23		
Grow-finish, 150 lbs.	6	5	6	4.1	Finishing, 900 lbs.	132	66	132	11		
Gestation, 400 lbs.	5	4	5	3.7	Feeder calves, 500 lbs.	73	37	73	6.11		
Sow and litter ^a , 450 lbs.	11	8	11	7.5	Open lot (solids - scraped)						
Farrow-nursery ^b	8	6	8	5.4	Beef, 400 sq. ft./hd.	66	48	42	3		
Farrow-finish ^c	44	33	44	30	Dairy, 1,000 sq. ft./hd.	127	69	127	11.5		
Dairy—confined				Swine, 50 sq. ft./hd.				18	17	11	1.2
Cows, 1,200 lbs. or more	59	44	59	40.1	POULTRY						
Heifers, 900 lbs.	44	33	44	29.9	--- lbs./1,000/yr. ---			birds T./1,000/yr.			
Calves, 500 lbs.	24	18	24	16.5	Layer, caged, 4 lbs.	367	840	525	10.5		
Veal calves, 250 lbs.	12	9	12	8.2	Broiler, litter, 2 lbs.	585	585	405	9.0		
Dairy herd ^d	87	66	87	59.8							
Beef—confined											
Mature cows, 1,000 lbs.	23	17	23	15.7							
Finishing, 900 lbs.	19	14	19	13.1							
Feeder calves, 500 lbs.	11	8	11	7.3							

^a Sow and litter figures are per farrowing crate.

^b Farrow-nursery figures are per sow in the breeding herd and include one farrowing sow, five gestation sows, and nine nursery pig spaces.

^c Farrow-finish figures are per sow in the breeding herd and include one farrowing sow, five gestation sows, nine nursery pigs, and 36 finishing pig spaces.

^d Per productive cow in the herd; includes lactating cow, 330 days; dry cow, 35 days; heifer, 222 days; and calf, 165 days.

^e Weights assumed: beef, 1,000 pounds; dairy, 1,200 pounds; swine, 150 pounds.

managing manure nutrients for crop production

TABLE 4

**CORRECTION FACTORS TO ACCOUNT FOR NITROGEN VOLATILIZATION
LOSSES DURING LAND APPLICATION OF ANIMAL MANURE**

APPLICATION METHOD	CORRECTION FACTOR
Direct injection	0.98
Broadcast and incorporate within 24 hours	0.95
Broadcast and incorporate after 24 hours	0.80
Broadcast liquid, no incorporation	0.75
Broadcast dry, no incorporation	0.70
Irrigation, no incorporation	0.60

Source: Iowa Department of Natural Resources

TABLE 5

NUTRIENT REMOVAL FOR IOWA CROPS

----- Pounds/Unit -----

CROP	UNITS	N	P ₂ O ₅	K ₂ O
Corn	bu.	-	0.375	0.3
Corn Silage	ton (65% H ₂ O)	-	3.5	6.5
Soybeans	bu.	3.8	0.8	1.5
Alfalfa	ton	50	12.5	40
Oat and Straw	bu.	0.75	0.4	1.0
Wheat	bu.	1.3	0.6	0.3
Smooth brome grass	ton	40	9	47
Orchardgrass	ton	38	14	68
Tall fescue	ton	38	12	66
Switch grass	ton	21	12	66
Sorghum-sudan	ton	40	12	38
Vetch	ton	56	12	47
Red clover	ton	43	10	33
Perennial ryegrass	ton	24	12	34
Timothy	ton	25	9	32
Wheat straw	ton	13	4	25
Oat straw	ton	12	5	33

managing manure nutrients for crop production

TABLE 6

**NITROGEN FERTILIZER RECOMMENDATIONS FOR MANURED^a
SOILS AND CORN AFTER ALFALFA**

(from Blackmer, Voss, and Mallarino, 1997)

GRAIN AND FERTILIZER PRICES	SOIL TEST NITRATE	----- Recommended N rate -----	
		EXCESS ^b RAINFALL	NORMAL RAINFALL
	ppm N	lbs. N/acre	lbs. N/acre
Unfavorable (1 bu. buys 7 lbs. of N)	0-10	90	90
	11-15	0	60
	16-20	0	0 ^c
	>20	0	0
Favorable (1 bu. buys 15 lbs. of N)	0-10	90	90
	11-15	60	60
	16-25	0	30
	>25	0	0

^a A field should be considered manured if animal manures were applied with a reasonable degree of uniformity since harvest of the previous crop or in two of the past four

TABLE 7

**PRIORITY RANKING OF FIELDS FOR ANIMALS MANURE APPLICATION
BASED ON SOIL TEST FOR PHOSPHORUS AND POTASSIUM AND THE
CROP TO BE GROWN**

SOIL TEST	A GROUP ^a	B GROUP ^b
Very Low	1	3
Low	2	4
Optimum	5	6
High	7	8
Very High	9	10

^a Corn, sorghum, oats, wheat, sunflowers

^b Soybean, alfalfa



land application

Land application of manure is such an important part of livestock operation that it ranks second only to uncontrolled discharges in potential environmental impact.

When manure is removed from storage it is spread on hundreds of times the area it previously occupied during storage. For example, manure from a 1,000-head, 40- x 200-foot finishing pit (0.2 acres) normally will be spread on more than 140 acres—700 times as much area as it occupies in the pit.

Improper land application can spoil the environment and cost—both the producer and society—financially.

Proper land application can enhance the environment and save money. This is achieved by applying the manure at the correct rate while considering the manure, the soil, the topography, the weather, the neighbors, nearby water sources, and other pertinent factors.

ENVIRONMENTAL SAFETY

The fundamental environmental rule that applies to all confinement feeding operations in Iowa is “confinement operations must retain all manure produced in the confinement enclosures between periods of manure application. In no case shall manure from a confinement feeding operation be discharged directly into the water of the state.”

Manure application guidelines

The IDNR rules recommend the following manure application practices for all livestock operations, including confinement operations and open feedlots:

- To minimize the potential for leaching to groundwater, or runoff to surface waters, nitrogen application from all sources, including manure, legumes, and commercial fertilizers, must not exceed the nitrogen use levels necessary to obtain optimum crop yields for the crop being grown.
- To minimize phosphorous movement to

surface waters, manure should be applied at rates not exceeding crop uptake of phosphorus when soil tests indicate adequate phosphorous levels. Phosphorous application may be greater than crop removal for maximum crop production when soil tests indicate very low or low phosphorous levels.

- Manure application on frozen or snow-covered crop land should be avoided whenever possible. If manure is spread on frozen or snow-covered crop land, application should be limited to areas on which
 - land slopes are 4 percent or less and
 - adequate erosion control practices exist.
- Manure applied on crop land subject to flooding more than once every 10 years should be incorporated into the soil after application.
- Unless adequate erosion controls are used and unless manure is injected or incorporated, manure should not be applied within 200 feet of land draining into a stream or surface intake for a tile line or other buried conduit. Manure should not be applied on waterways.
- Injection or soil incorporation of manure is recommended where consistent with established soil erosion control practices.

LIQUID MANURE APPLICATION SYSTEMS

Injection systems

Manure injection systems are designed to place the manure under the soil and cover it. This method of applying manure has a number of benefits, including

- Reduced nitrogen volatilization losses;
- Reduced threat of runoff losses of nutrients and microbes;

land application

- Reduced tillage trips due to the tillage benefits from the injectors; and
- Reduced odor during land application.

When injecting manure, application rates should be lower than broadcast rates since very little nitrogen is lost in the air.

Figure 1 (see *land application page 18*) shows ideal parameters for designing manure injection equipment.

There also are potential adverse effects of manure injection. In particular, injection can disturb the soil surface, which can significantly cover crop residue in no-till or conservation tillage systems.

Soil residue reduction varies from about 30 to 60 percent depending on the manure application system. Iowa State University data has shown corn residue remaining after injection varies from 30 to 85 percent with different injectors. A number of factors influenced performance: size and type of tool, speed, depth, tool spacing, soil type, soil condition, and the consistency and care of the operator.

The tillage tool, including various attachments, significantly affects soil surface disturbance and distribution of liquid manure in the soil. Sweeps generally cause more of an uplift of soil than chisel points, but result in better manure distribution. Figures 2 and 3 (see *land application pages 18 and 19*) show the projected areas of the tillage tools, the regions of soil disturbance, and the saturated soil for typical chisel point and sweep injectors, respectively.

The shank width (not sweep width) perhaps has the greatest influence on residue disturbance and soil roughness. This width is constrained by the necessity of allowing the flow of liquid manure without clogging. The shank often can catch residue in a hairpin fashion and hinder plowing performance. Placing a coulter in front of the shank (see *Figure 4, land application page 19*) can help by cutting through the residue and creating a path for the shank to follow. However, in some cases the residue may be so thick that even the coulter becomes clogged. Closing disks or some other device may help

keep soil in a restricted region, thereby preventing some of the residue coverage. (See *figures 5-7, land application pages 20 and 21.*)

Adjust your tractor speed to provide the best performance of the tillage implement. However, you must consider the time required to dispose of manure and the desired application rate (gallons/acre). Flow control may be necessary to achieve the desired application rate and to operate at an optimal speed for the best performance of the tillage implement. Some manure application systems have this feature. Umbilical systems which operate with a secondary power unit, such as another tractor driving the pump, allow for flow control. Other systems include attachments with orifice-type restrictions to control flow. Because more precise application rates and calibration likely will be required, future designs should include flow control features that allow you to set your desired speed and flow rate. Injector spacing also greatly affects performance. Keep in mind the following considerations:

- Less residue is destroyed as the spacing is increased.
- Wider spacing results in greater manure flow through each injector and less uniformity, but facilitates covering more ground faster.
- Planting too close to “hot spots,” or areas with high concentrations of liquid manure, can adversely affect plant growth, particularly if the manure is injected in the spring. Sweeps help avoid hot spots, but also affect residue retention.

Broadcast systems

There are three systems used to broadcast manure:

- Liquid tank spreaders,
- Dry spreaders, and
- Irrigation systems.

Each of these systems has two major management concerns: applying the manure at the

land application

proper rate and achieving uniform distribution. In general, application patterns for broadcast systems tend to be less uniform than for injection systems.

For liquid tank and dry spreaders, application patterns typically are high in the center (behind the spreader) and taper down toward the edges. This is especially true for dry box spreaders. To achieve a uniform application and avoid streaked crops, the edges must be overlapped. The amount of overlap will be determined by the particular machine and its specific distribution characteristics. The amount of overlap in turn affects the overall application rate, because it affects the distance between passes; this is also true of traveling gun irrigation systems. Other factors that can distort application patterns are wind, sloping ground, and partial plugging. Center pivot irrigation systems are less sensitive to these problems because they are typically designed for “whole field” coverage. Good management is required in all cases to achieve uniform application at the right rate when broadcasting manure.

Irrigation systems

Although irrigation is not used as extensively in Iowa as some other states, its use is increasing. The potential for crop damage and environmental pollution by lagoon liquid irrigation systems requires additional knowledge and management.

Use irrigation scheduling (the management routine used to accomplish the right balance) to answer these questions:

- Do I need to irrigate?
- How much should I apply?

DETERMINING THE PROPER RATE

Applying manure at the correct rate is the most important element of environmentally friendly manure management. Use your nutrient management plan to determine your manure application rate. Instructions for developing a nutrient management plan can be found in the nutrients management section. (**Note:** Developing the

plan is the responsibility of the producer.) Next, apply the gallons or tons per acre of manure to supply the nutrients called for in the plan. (**Note:** Applying the correct amount of manure according to the plan is the responsibility of the applicator.)

Manure from different types of storage systems (pits, lagoons, or dry manure) must be applied at different rates because of varying nutrient contents. (*See Table 2, nutrient management section page 7.*)

- Pit manure is relatively concentrated and is typically applied at 2,000 to 8,000 gallons/acre.
- Lagoon liquid is relatively dilute and is typically applied at 20,000 to 50,000 gallons/acre.
- Dry poultry layer manure typically is applied at 5 to 15 tons/acre.
- Dry bedded manure is applied at 10 to 25 tons/acre.

The actual rates should be determined by your manure management plan and the actual nutrient concentration of the manure.

Example:

Your manure nutrient plan calls for 140 pounds N/acre from the manure you will apply. Your pit manure contains 50 pounds/1,000 gallons and will contribute 49 pounds after deducting 2 percent losses from injection ($0.98 \times 50 = 49$). Your application rate should be:

$$(140/49) \times 1,000 = 2,857 \text{ gals./acre using manure from a pit}$$

If you pump through a drag hose injection system from a lagoon that contains only 4 pounds/1,000 gallons your application rate should be:

$$(140/4) \times 1,000 = 35,000 \text{ gals./acre using manure from a lagoon}$$

(27,000 gals./acre is equivalent to a 1-inch rain.)

land application

The manure's nutrient concentration is critical to determining how much manure to apply. However, the soil's capacity for holding water, rather than the amount of nutrients, often limits the amount of lagoon liquid to be applied. In the example above, 35,000 gallons/acre is too much to apply at once. It must be applied in two or more applications.

Example:

You are applying solid manure from a high-rise layer house. Each ton contains 35 pounds N. Calculate the application rate to supply 120 pounds/acre to the land. Since the manure will be broadcast, you will retain 70 percent of the N (*see Table 4, nutrients management section page 9.*)

After deducting the application loss your manure will contain:

$$35 \times 0.7 = 24.5 \text{ lbs. N/ton}$$

You should apply:

$$120/24.5 = 4.9 \text{ tons/acre}$$

SOIL-WATER RELATIONSHIPS

Before attempting to measure or estimate soil-water content, you should understand some basic soil-water relationships:

Soil is composed of three major parts: air, water, and solids.

Pore volume is that portion of soil occupied by air and water.

Saturation occurs when all soil pores are filled with water. Any water added to the soil under this condition will either run off or leach below the root zone. Saturated conditions are undesirable for good crop growth or any additional liquid application.

Field capacity is the point at which the soil has

had time to drain away excess water from the large pores by gravity, but still remains in a very moist condition.

Wilting point occurs when there is so little water left in the soil that plants cannot remove the water for their use.

Not all of the water added to soil is retained for plant use. Lagoon water should be applied so that it remains in the root zone for uptake by the crop. Any water not retained in the root zone can transport nutrients to surface water, groundwater, or both.

To interpret soil-water measurements and apply them to irrigation scheduling, you must be able to distinguish between two categories of soil water:

- **Gravitational water** is the water in the soil that is free to drain or move by the force of gravity. Gravitational water is computed as the volume of water in the soil between saturation and field capacity. When gravitational water is present in the root zone, the soil is too wet to be irrigated.
- **Plant-available water (PAW)** is the amount of water held in the soil that is available to plants. PAW is the difference between the water content at field capacity (referred to as the upper limit water content) and the permanent wilting point (often referred to as the lower limit water content).

Schedule applications to maintain the water content of the soil between these two extremes. If there is no PAW deficit, gravitational water likely is present, and wastewater irrigation should be delayed under normal operating conditions.

Soil texture greatly influences the portion of the soil pore volume that can be occupied by gravitational water or plant-available water; therefore, it is important to know your soil texture to determine how much water can be applied.

land application

The amount of plant-available water that exists in the soil at any given time is commonly known as the “depth of water per unit depth of soil.” Typical units are inches of PAW per foot of soil depth. Plant-available water estimates for various soil textural classes are given in published soil survey reports. These estimates range from less than 0.2 inch of PAW per foot of soil for coarse sandy soils to nearly 2.0 inches of PAW per foot of soil for silty and clay soils.

Estimating soil-water content

At the start of application, the water content in the soil should be lower than the field capacity (upper limit). The difference between the existing water content and the field capacity water content is the most that should be applied. The drier the soil, the more liquid that can be safely applied per application, provided this amount does not exceed the required nitrogen application rate. Determining the water content of the soil tells you if the soil is dry enough and, if so, how much liquid can be applied. Use one of the three following methods to estimate the amount of water present in the soil:

- 1. Feel method.** Squeeze a ball of soil in your hand and consult a chart for the particular soil about how much moisture is contained in the soil and therefore how much, if any, application can take place. (*See Table 1, land application page 22.*)
- 2. Soil moisture measurement devices.** This method uses one or more instruments to directly measure soil moisture. While an in-depth discussion of the various types of instruments is beyond the scope of this chapter, you should be aware that they exist and are appropriate for certain soil types and application situations. Consult Extension Ag Engineers and publications on irrigation for more information.
- 3. Checkbook method for irrigation.** This is an accounting approach for estimating how much soil water remains in the effective root zone. Wastewater irrigation is scheduled when the soil-water content in the root zone drops below a threshold level.

Some of the simpler checkbook methods track rainfall, evapotranspiration, and irrigation amounts. More sophisticated methods require periodic measurements of the soil-water status and moisture use rates of the crop. Checkbook methods require daily record keeping; this can, however, be programmed on a computer. Software has been developed to handle the accounting in a timely manner and recommend precise irrigation schedules. The checkbook method requires that you begin the soil-water computations when the soil is at a known water content (This is similar to knowing the beginning balance of your checking account before you start making deposits and withdrawals.) The method also requires a local, up-to-the-minute source of data on evapotranspiration.

You should select the method that is appropriate for the soils and crops, and with which you are most comfortable.

Scheduling irrigation

Irrigation should be scheduled and managed so that

- No surface runoff occurs during irrigation;
- The root zone is not completely saturated at the end of the irrigation cycle; and
- The irrigated water does not leach below the root zone.

The amount that can or should be applied during any single irrigation cycle is controlled by how much water the soil can absorb. This varies from day to day and is influenced by

- Rainfall (when and how much it last rained, the forecast—don’t try to beat the rain);
- Crop maturity (water uptake rate of the crop);
- Soil type (texture, structure, depth, and cover);

land application

- Effective root zone depth; and
- Evapotranspiration, which in turn is influenced by temperature, wind, and relative humidity.

Irrigation should replace the water that has evaporated from the soil or been removed by plants. This is the plant-available water deficit. Most water taken up by plants is removed in the upper half of the root zone. For the purpose of scheduling irrigation, this zone is referred to as the effective root zone depth. Soil conditions in Iowa vary widely. The rooting depths of crops in some of the clay pan soils may be only eight inches, so the effective root zone depth is about half that, or four inches. In deep soils the rooting depth may be in up to five feet. Estimate or measure the plant-available water deficit to be replaced by irrigation within this range. If the irrigation volume applied exceeds the PAW deficit, the excess either runs off or leaches below the root zone and could contaminate groundwater.

Nutrient tests and a manure nutrient plan will help determine whether nutrients or liquid volume will be the most limiting. Generally, you should not apply more than about an inch of wastewater during any single irrigation cycle. Even this amount may be too high and is not recommended for some soils.

The soil intake rate is the rate at which the soil can absorb the irrigated liquid. The soil intake rate decreases the longer water is applied. (See Figure 8, *land application* page 22.) The intake rate of most clay or silty soils begins to be exceeded by the time 0.5 to 0.6 inch has been applied. Continuing to irrigate beyond this amount could result in surface ponding and possible runoff, which is a violation of water quality law. Soil intake rate also depends on the crop type, plant population, soil slope, soil surface condition, and soil residue cover.

When all of the above factors are taken into account, recommended wastewater irrigation amounts for a single irrigation cycle are in the range of 0.25 to 0.75 inch per foot of effective root zone depth.

Regardless of the calculated rate, you, as the system operator, should monitor each lagoon water application to verify adequate infiltration of the water into the soil. An irrigation cycle should be stopped if ponding and runoff start to occur, or if any changes occur in drainage tile efficiency from the irrigated area.

Understanding your system

A key element of irrigation system design is the proper combination of system components so that the system application rate does not exceed the intake rate of the soil.

Discharge rate is the volume of water leaving a sprinkler per unit of time. Discharge rates normally are expressed in terms of gallons per minute (gpm). Manufacturers publish discharge rates for their sprinklers as a function of the operating pressure and orifice diameter of the nozzle. You should always have a copy of the manufacturer's discharge specifications for the sprinklers in your system. Discharge characteristics of typical BIG GUN™ sprinklers are given in Table 2 (see *land application* page 23).

Application rate normally is expressed as unit depth of water (inch) per unit of time (usually an hour). The application rate depends upon discharge rate and coverage diameter. It is computed by first converting the discharge rate to a unit depth of water (inch) per unit of area (such as acre or square feet), then dividing by the wetted area of the sprinkler. Another important parameter is total application volume (inch), which is computed based on the amount of time the system operates at a given rate on a given field. Your target application rate represents the total volume (gallons/acre) needed to satisfy the plant-available nitrogen needs of the crop. This application rate is used for planning; rarely can you apply this much water during one irrigation cycle.

- **Determining application rates for stationary big gun and rotary**

land application

impact sprinklers

The application rate for stationary sprinklers is computed as follows:

1. Determine the discharge rate and wetted diameter from manufacturer's literature.
2. Determine recommended sprinkler spacing (usually 50 to 70 percent of wetted diameter). Sprinklers normally are spaced in equal multiples of 20 feet based on typical pipe section length.
3. Compute the application rate by the formula:

$$\text{Application rate, in./hr} = \frac{(96 \times \text{Discharge rate, gpm})}{(\text{Sprinkler width, ft.} \times \text{Sprinkler spacing, ft.})}$$

The application volume is then computed as the application rate multiplied by the operating time. In many cases, you will compute the desired application volume to achieve a desired amount of nitrogen application. If this is the case, you then compute the time required to operate the system to achieve the desired application volume.

- **Determining application rates for traveling gun sprinklers**

The volume of wastewater applied by a traveling gun depends on the flow rate, lane spacing, travel distance, and travel speed. A procedure to calibrate a traveling BIG GUN47 sprinkler is given below. The travel lane spacing should be approximately 70 to 80 percent of the sprinkler's wetted diameter (see Figure 9, land application page 23).

Determine the application depth in inches from the manufacturer's literature or Table 2 (see land application page 23). To determine the appropriate travel speed to deliver a known waste application depth, use the following formula:

$$\text{Travel speed} = \frac{(19.26 \times \text{Sprinkler flow rate, gpm})}{(\text{Lane spacing, ft.} \times \text{Application depth, in.})}$$

To ensure the accuracy of this calculation, occasionally measure the actual application amounts. You can do this with rain gauges or by simply measuring the depth of wastewater caught in pans or buckets placed in the irrigation field. Take several measurements at various areas during irrigation and use an average to determine the irrigation depth.

NOTE: Table 2 and the travel speed equation assume the gun is turning full circle. If the gun is operating at part circle, then the travel speed should be increased accordingly to provide the planned application rate.

CALIBRATION

Calibrating liquid tank spreaders

If the tank discharge is by gravity, a full tank will apply manure somewhat more rapidly than a nearly empty tank. Manure solids content also will also affect the application rate. Ideally, you should perform a spreader calibration for each manure source to get an idea of the variability between application rates.

- **Volume method**

The simplest way to calibrate a liquid manure spreader is to apply all the manure in a fully loaded spreader and then calculate the field area covered by that load. Divide the spreader volume by the acreage covered to get the gallons/acre. This is an average rate over the entire load. Some tank spreaders have an indicator for the manure volume remaining; calibration can then be done over a smaller portion of the load.

To determine the acreage covered, you need to know the width of the swath and the distance traveled. Swath width is the distance between the centerline locations of the spreader on two successive passes. This center-distance method accounts for any overlap or underlap. One simple way to measure the distance traveled is to mark a wheel and count revolutions during the application. (A front wheel can be used if the tractor cab obscures the view of the rear wheels.) Next, multiply the number of revolutions by the distance traveled for each revolution. The gallons applied per acre can now be calculated.

land application

The equation is

Gallons/acre =
(Gallons x 43,560)/(Swath length x Swath width)

Example:

You applied 3,000 gallons in one half mile pass (2,640 feet) with a spreader that covers a 15 foot swath width.

$$\begin{aligned} \text{Gallons/acre} &= 3,000 \times 43,560 / 2,640 \times 15 \\ &= 3,300 \text{ gals/acre} \end{aligned}$$

(Also see Table 3, land application page 24 for this information.)

• Weight method

Use scales to weigh the spreader before and after manure application; then divide the net weight by the acreage covered. To calculate the gallons/acre application rate, assume an average density (weight per gallon) of the manure. The “Liquid manure in spreader, weight method,” equation in Table 3 (see land application page 24) assumes a density of about 62 pounds/cubic foot (8.3 pounds/gallon).

• More about liquid spreaders

Liquid spreaders with injection toolbars should be calibrated at more than one ground speed to account for the effects of speed on injector device delivery. Consider calibrating at several tractor gear ratios and note the results. Remember that over a limited range, you can alter manure application rates by changing ground speed. You can determine a new driving speed to achieve a desired new application rate.

The equation is

New speed =
Original speed x (Original rate/New rate)

Or you can determine your new application rate after changing ground speeds.

The equation is

New rate =
Original rate x (Original speed/New speed)

Table 4 (see land application page 25) shows application rates for various swath widths, lengths, and volumes.

Example:

You were driving 5 mph to apply the 3,300 gallons per acre. How fast should you go to apply 3,000 gallons per acre?

$$\begin{aligned} \text{New speed} &= 5.0 \times 3,300 / 3,000 \\ &= 5.5 \text{ mph} \end{aligned}$$

Flow sensors and flow controllers can be used to monitor and maintain your application rate, regardless of speed changes. While expensive (approximately \$6,000), the devices are a worthwhile investment if you will be applying large quantities of liquid manure. In the future they will interface with variable application rate equipment for even better control.

Calibrating solid and semisolid manure spreaders

• Volume method

Box-type spreader manufacturers publish one or more spreader volumetric capacities, including the struck (level-full) capacity and the heaped capacity. Be sure to use the correct capacity number that corresponds to how the spreader is loaded. Spread a full load, noting the distance traveled and the swath width, as in the preceding section on liquid spreaders. The tons per acre application rate can be calculated

land application

as shown below.

The equation is

$$\text{Tons/acre} = \frac{\text{Bushels} \times 1,688}{\text{Swath length} \times \text{Width}}$$

The above equation assumes a solid manure density of 62 pounds/cubic foot. If there is much bedding in the manure, you may be applying only about 90 percent of the calculated amount because of the reduced manure density.

- **Sampled weight method**

This method samples the application rate by catching manure on one or more plastic sheets placed on the ground in the path of the spreader. You may use any size of rectangular plastic sheet, but a few convenient sizes make calculation very easy: 9 x 12 feet for light application rates, and 56 inches square or 36 x 87 inches for heavier rates. The 9 x 12 feet and 36 x 87 inches are convenient sizes if the plastic material comes in 12-foot-wide rolls.

Place a plastic sheet in the bucket or tub and weigh the sheet and container for the tare weight. Place the sheet or sheets in the field to get a representative sampling across the width of the spreader swath. Begin spreading well before you reach the plastic sheets and drive the spreader at a normal speed over the plastic. Gather up each plastic sheet, place it in the bucket or tub, weigh it, and subtract the tare weight. For best results, take the average of at least three weights. The manure application rate in tons per acre is figured from the equation in Table 3 (see *land application page 24*). Note that the weight of manure on the 9 x 12 foot sheet is divided by 5 to get the tons per acre.

Tons/acre = pounds/5
The weight of manure on the smaller “convenience” sizes (36 x 87 inches and 56 inches square) requires no conversion.

Tons per acre =
pounds of manure on the sheet

- **More about solid and semisolid**

manure spreaders

Calibrate with different spreader settings and different tractor ground speeds to get a range of application rates. You should build a table of rates that will enable you to apply at nearly any rate required by the farm’s manure nutrient management plan.

Reliability and quality of calibration results

Spreader application rates vary somewhat according to the ground slope, manure consistency, and the amount and type of bedding. The rates also vary across the swath width, with some spreaders accounting for overlap from adjacent rounds. Most equipment delivers a rate that decreases during application. Until equipment is built that regulates application rate more closely, the burden is on the operator to become familiar with the spreader’s characteristics.

A reasonable target for calibration precision is about +/- 10 to 20 percent. This target balances the uncertainty in the manure nutrient laboratory analysis with factors such as sampling error, soil variability, and differences in plant nutrient uptake. As with any sampling procedure, a single calibration reading is better than none, but multiple calibrations increase precision. However, there is a point of diminishing returns, when the labor required to perform the calibration does not pay off in improved precision.

Calibrating irrigation systems

Manufacturers’ literature and charts apply to new equipment. Discharge rates and application rates change over time as equipment gets older and components begin to wear. Pump wear tends to reduce operating pressure and flow. Nozzle wear increases the nozzle opening, which increases the discharge rate while decreasing the wetted diameter.

Operating the system differently than assumed in the design will alter the application rate, diameter of coverage, and subsequently, the application uniformity. For example, operating the system with excessive pressure produces smaller droplets

land application

and greater potential for drift, and accelerates wear of the sprinkler nozzle. Clogged nozzles can increase pressure. Plugged intakes or crystallized mainlines reduce operating pressure. Operating below design pressure greatly reduces the coverage diameter and application uniformity.

To ensure proper calibration and uniform coverage you should calibrate your equipment at least once every three years. To calibrate, collect, and measure flow at several locations in the application area, use a container to collect flow and determine the application rate. Rain gauges work well because they already have a graduated scale from which to read the application amount without having to perform additional calculations. However, you can use anything with a uniform opening and cross section (such as a pan or jar) if the collected liquid can be transferred to a scaled container for measuring.

To calibrate stationary sprinklers, place collection containers randomly throughout the application area at several distances from the sprinklers. For traveling guns, place containers along a transect perpendicular to the direction of pull. Place collection containers 25 feet apart along the transect on both sides of the gun cart. Compute the average application rate for all collection containers.

Also look for evidence of the application's nonuniformity. On a windless day, variation between containers of more than 30 percent is cause for concern: you should contact your irrigation dealer or technical specialist for assistance.

ENVIRONMENTAL ISSUES

Applying manure on frozen or snow-covered ground

Manure, especially liquid manure, should not be applied on frozen or snow-covered ground because any liquid applied to frozen ground has the potential to run off. A basic equation explains the problem:

Runoff =

Application - Infiltration - Temporary surface storage

This equation is used with all liquid application systems to prevent runoff. Iowa soils typically have infiltration rates ranging from 0.2 to 2.0 inches/hour. As long as the application rate does not exceed the infiltration rate, no runoff occurs. When the soil is frozen, however, the infiltration rate is zero, so the equation becomes

Runoff =
Application - 0 - Temporary surface storage

Runoff =
Application - Temporary surface storage

NOTE: Runoff is very likely to occur when applied on frozen soils. The greater the slope, the less the surface storage and the greater the potential for runoff.

If you must apply on frozen soils, try to make the application

- Early in the winter or
- After the snow melts in the late winter, and
- Only on flat ground.

ISU research has shown that runoff and nutrient losses are greatest from manure applied on top of snow late in the winter just before the snow melts. Much lower losses resulted from manure applied to the soil than from manure applied to the snow.

Example:

DNR has had several cases where manure was applied to frozen, snow covered ground. When the temperature rose into the 50s within several days discharges to tiles and streams resulted.

Separation distance is another factor to consider when applying manure to frozen ground. Except for SAFOs, Iowa law now requires a 750-foot separation distance from neighboring residences, businesses, and public areas for broadcast liquid manure from confinement operations larger than SAFOs, that is not incorporated within 24 hours.

land application

This requirement is always in effect when the ground is frozen because you cannot incorporate the manure.

Solid manure is less risky to apply to frozen ground than liquid manure. Solid manure sometimes even acts as a mulch on tilled ground. However, risk is still involved, and the same care should be taken as with liquid manure: apply early or late in the winter season on soil rather than snow. Limit applications to flat ground.

Controlling soil erosion

While soil erosion is a natural process, it can have detrimental effects when accelerated by human activities such as manure application. Soil erosion can cause

- The loss of the most productive part of the soil,
- The loss of applied fertilizers (including manure) and chemicals,
- Seed to be washed out or covered by sediment, and
- Sediment deposits that choke road and farm ditches, lakes, and rivers. (Sediment is the greatest pollutant by volume in Iowa.)

You can reduce soil losses to a tolerable level by using conservation farming. In some cases a system to control erosion simply may consist of a crop rotation that includes row crops, small grain, and hay. If you wish to grow all row crops, you may need to incorporate no-till farming and contour farming into your system, depending on the soil type, slope steepness, and slope length. Building terraces and contouring could enable you to do some tillage rather than no-till using the same rotation.

The Food Security Act of 1985 requires a certain level of soil erosion control of farmers who want to participate in U.S. Department of Agriculture programs. Farmers on highly erodible land (HEL), land with high erodibility due to

inherent soil erodibility, rainfall energy, and slope steepness and length, must control soil loss to at least an alternative conservation system level. Alternative conservation systems achieve significant soil loss reduction and are technically and economically feasible. They are intended only to maintain compliance for federal farm programs. Often, even more intensive systems are needed to control soil loss to tolerable levels (T). Unless erosion is controlled to T, productivity and nutrients from the manure will still be lost and water quality reduced. Systems that control soil loss to T can be developed with the Natural Resources Conservation Service or Soil and Water Conservation District.

Manure application can greatly affect soil erosion. The degree of influence generally is related to the application method and what must be done to the soil afterwards to prepare it for planting.

Liquid manure injection can disturb too much soil, cover crop residue, and leave the surface rough. This poses a problem for farmers on HEL who plan to control erosion with crop residue. Often, if they till the soil enough to work in the manure or smooth the surface for planting, there is not enough crop residue left to provide the protection they need. DNR rules require a copy of the conservation plan to accompany manure management plans that include HEL land.

Livestock producers who farm HEL fields do have options to help them maintain their eligibility for federal farm programs. They may

- Apply manure to fields that are not highly erodible (NHEL).
- Apply manure to flat areas of HEL fields.
- Use a rotation and/or additional conservation practices such as contouring or buffer strips that will allow lower residue requirements.

land application

- Surface apply manure.
- Use equipment that injects manure but leaves the residue intact and the surface level enough to plant without further tillage. As previously noted, injection equipment has been developed that will function in a no-till system.

Irrigation systems and neighbors

Sprinkler irrigation systems can cause serious nuisance problems even if the systems are operated in accordance with the state law.

Irrigation systems can be designed to handle liquid waste ranging from clean water containing no solids to raw manure containing more than 5 percent solids. This broad range of capability must not be exploited to the extent that the irrigation system becomes a nuisance to neighbors. You must be especially conscious of neighbors when you are irrigating liquid that has inherent odors. Raw manure is the most potent, followed by lagoon sludge, lagoon supernatant (the liquid at the top of the lagoon), and holding pond water. DNR rules require manure from pits or earthen basins to be diluted 15:1 with fresh water to be irrigated with high pressure (>80psi) systems. Five categories of nuisance or pollution potential should concern you as the irrigation system operator:

- 1. Surface water pollution due to runoff.**
Pay close attention to soil conditions and the operation of the irrigation equipment. Apply wastewater evenly and never in amounts that cause ponding or runoff. Observe the recommended or required buffer distances from streams, roads, property lines, and designated areas.
- 2. Groundwater pollution from overapplication** causing nutrients to leach.
- 3. Overspray onto roads and other property.**
Although the overspray might be light enough to avoid water pollution, overspray can be construed as a nuisance and a sign of poor management and an insensitive livestock facility manager. Off-site drift is a violation of DNR rules which require a minimum 100 foot separation distance

from adjacent properties.

- 4. Odor.** Be very attentive to weather conditions and timing. Select days when there will be strong sunlight in early morning and light winds.
- 5. Droplet drift.** Use low-trajectory nozzles to keep droplets low to the ground; use large tapered-bore nozzles (not ring-type) and the lowest operating pressures possible to reduce the amount of fine droplets produced.

Prevent releases when handling pipes

Irrigation and umbilical system pipes can hold large amounts of liquid. Several releases have been recorded from drainbacks when the pipes were taken apart, or came apart accidentally. An especially sensitive situation exists when a tile intake or water body are nearby. The following table shows how much liquid pipes of different diameters can hold.

Pipe diameter	gal./ft.	gal./660 ft.	gal./mile
4	0.7	430.8	3446.5
5	1.0	673.2	5385.2
6	1.5	969.3	7754.4
7	2.0	1319.4	10555.0
8	2.6	1723.3	13786.1

A mile-long five inch diameter pipe hold over 5,000 gallons of liquid. If it held concentrated pit manure, releasing the pipe contents near any sensitive area could cause a major environmental problem.

EXAMPLES OF ACTUAL RELEASES

Releases are nearly always unplanned. They result from mistakes, inattention to detail, or simply

land application

failing to realize the potential consequences of actions. The following examples of releases, taken from IDNR files, are presented to help you anticipate some of the things that can happen during land application of manure.

- **Keep pipe joints as far from water resources as possible**

A custom applicator tried to repair a leaking umbilical cord joint that was located approximately 30 feet from a tile intake.

In the process, confinement hog manure entered the tile intake and resulted in a significant fish kill. In another instance a beef cattle confinement facility was transporting manure from an anaerobic lagoon to the application site across a river. A joint located within 10 feet of the river came apart, resulting in a large fish kill.

Lesson: Keep joints and other connections as far away from water resources as possible.

- **If a problem is identified, fix it immediately**

A producer was pumping an earthen basin. The pump hose had a hole in it and leaked manure during several days of pumping. Manure ponded in a low area and infiltrated to a nearby tile, ultimately discharging to a stream. The following year the same producer was pumping with the same hose, but had not repaired the hose. Manure leaked for several days while

pumping, ponded, and ran into a nearby tile intake in the road ditch approximately 30 feet from building. Manure discharged to a stream and resulted in a fish kill.

Lesson: Don't ignore known problems. Protect intakes near pumping sites.

- **Take appropriate preventative action and never leave operating equipment unattended**

A tile intake was located near a confinement building. The intake was previously plugged, but was unplugged for spring rains. Fall pumping began with the intake open. The producer temporarily left the operating pump, a hose failed, and manure from the building ran to the tile intake and was discharged to a stream.

Lesson: Never leave equipment unattended. Protect intakes near pumping sites.

- **Avoid overloading soil during lagoon applications**

A producer applied more than 30,000 gallons per acre from a lagoon. The soil could not hold that much liquid and manure infiltrated to tile lines and discharged to a stream.

Lesson: Don't apply more liquid than the soil can hold. If nutrient plans call for large volumes, more than one application may be necessary.

- **Watch the weather forecast before spreading**

A dairy operation (freestall barn) had an earthen manure storage basin sized for approximately one year of storage. In the spring the managers realized they would not make it until the fall harvest so they

land application

planted early corn. In the fall they instructed a custom pumper to apply the contents of the basin on those 40 acres. The overall application rate was between 20,000 to 25,000 gallons per acre with a drag line hose with incorporation discs. The ground was fairly steep. Two inches of rain was received within one-half hour after application and caused substantial runoff from the field. The runoff entered a creek and caused a fish kill for almost 12 miles.

Lesson: If a rain is predicted, delay application, especially on steep ground.

SUMMARY OF KEY POINTS

Next to preventing uncontrolled releases, proper land application is the most important factor affecting the environment.

- Manure rates should be determined by a manure nutrient plan.
- It is the producer's responsibility to develop and maintain the manure nutrient plan.
- It is the applicator's responsibility to apply the manure correctly.
- Advantages of injection include lower N volatilization losses, tillage benefits, reduced odor, and reduced threat of runoff losses of nutrients and microbes.
- Three broadcast systems are liquid, dry, and irrigation.
- Soil has three major components: solids, air, and water.
- Soil water content and forecast precipitation is very important in determining when and how much manure

to apply.

- Soil infiltration rates decrease with increasing time during a rainfall or irrigation event.
- Discharge rate and application rate are related, but are not the same.
- Discharge rate = gallons/minute.
- Application rate = gallons/acre.
- Either weight or volume can be used to calibrate spreaders.
- Don't apply more liquid than the soil can hold.
- $\text{Runoff} = \text{application} - \text{temporary surface storage} - \text{infiltration}$. If infiltration is zero, runoff will result when the application is greater than the surface storage.
- Soil erosion causes losses in fields and pollution in ditches, lakes, and rivers.
- Manure applied to the surface and incorporated or applied by injection can reduce residue cover and affect conservation compliance on highly erodible land (HEL). A disadvantage of injection is reduced crop residue cover, resulting in the increased threat of erosion.
- Conservation practices are available and can be applied to allow producers to apply manure and maintain compliance.
- Equipment is continually being developed and improved to inject manure and maintain residue cover.
- Watch the weather forecast. Don't try to "beat" the rain.

References

Block, W.A., R.K. Knipe, and S.L. Hollister. 1995. *Manure application on highly erodible land*. ASAE Paper no. 95-2412.

land application

*Block, W.A., R.K. Knipe, and D.C. Feltes. 1994.
Manure injection with conservation compliance.
Illinois Swine Seminar Proceedings 1994,
University of Illinois Cooperative Extension
Service.*

land application

land application

land application

FIGURE 1

IDEAL PARAMETERS OF MANURE INJECTION DESIGN

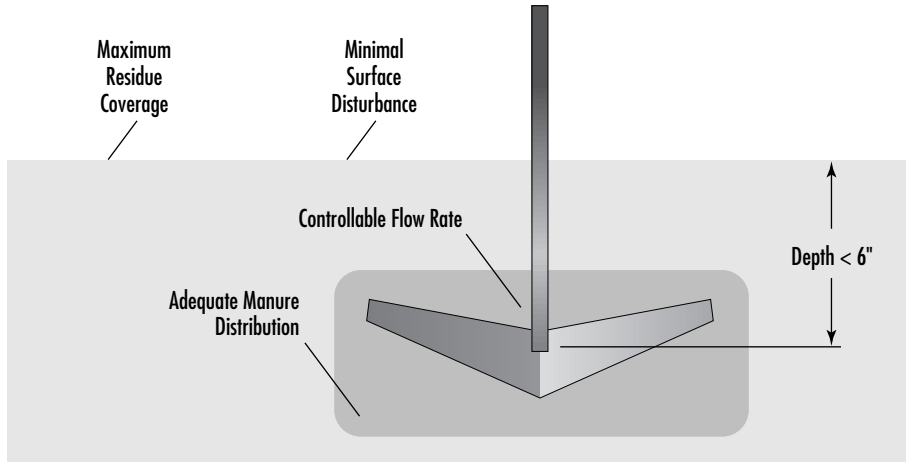
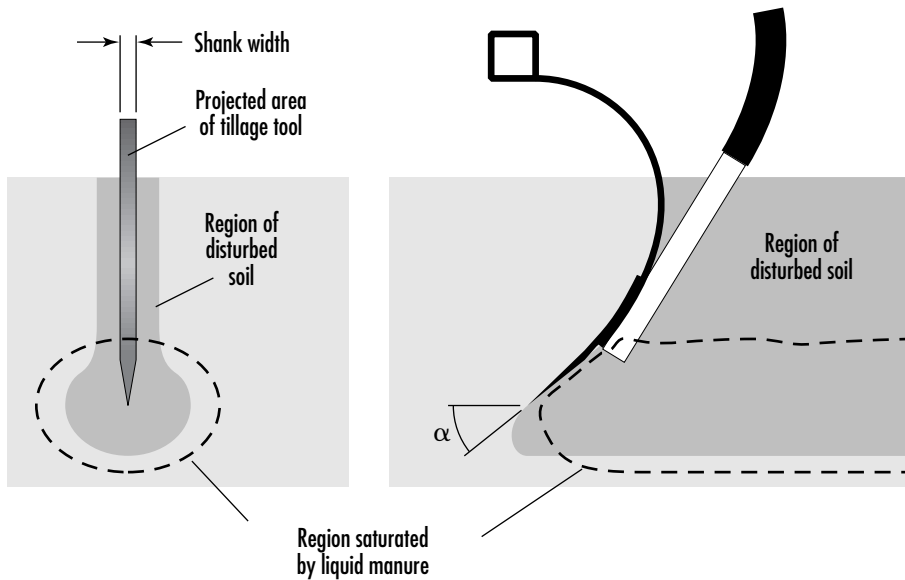

FIGURE 2

CHISEL POINT-TYPE INJECTOR

FRONT VIEW

SIDE VIEW



land application

FIGURE 3

SWEEP-TYPE INJECTOR

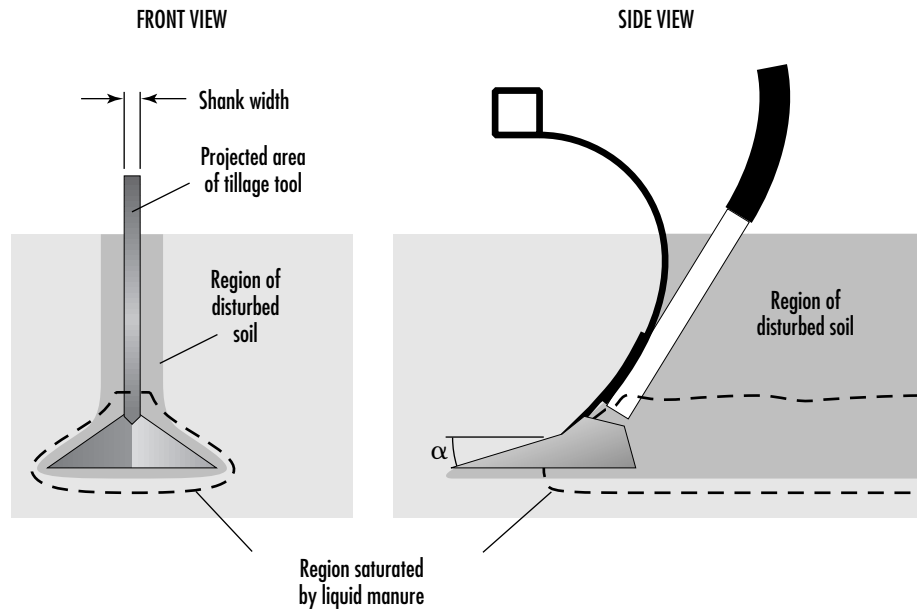
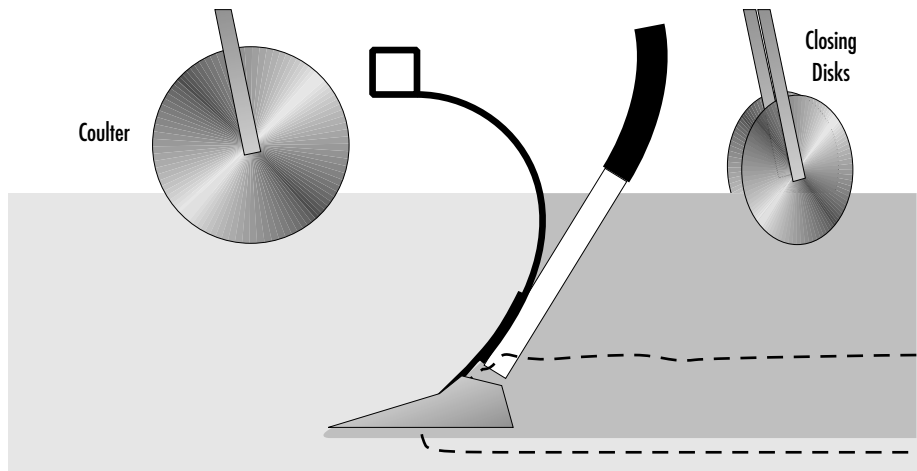

FIGURE 4

SWEEP-TYPE INJECTOR WITH COULTER AND CLOSING DISKS



land application

FIGURE 5

RESIDUE MEASUREMENTS AT ISU MANURE APPLICATION FIELD DAYS HAS SHOWN THAT UP TO 89 PERCENT OF THE RESIDUE CAN BE RETAINED BY THE SUKUP AND YETTER NO-TILL INJECTORS AND THE FARMSTAR NO-TILL INJECTOR.



land application

FIGURE 6

MANY OF THE SWEEPS RETAINED 60 PERCENT RESIDUE COVERAGE.



FIGURE 7

COVERING DISKS PERFORM WELL IN RESIDUE. RESIDUE COVERAGE DEPENDS ON HOW DEEP THEY ARE RUN.



land application

TABLE 1

BEHAVIOR OF SOIL AT SELECTED SOIL-WATER DEPLETION AMOUNTS

AVAILABLE WATER REMAINING IN THE SOIL	SOIL TYPE	
	SANDS	LOAMY SAND/SANDY LOAM
Soil saturated, wetter than field capacity	Free water appears when soil ball is squeezed	Free water appears when soil ball is squeezed
100% available (field capacity)	When soil ball is squeezed, wet outline on hand but no free water	When soil ball is squeezed, wet outline on hand but no free water
75 to 100%	Sticks together slightly	Forms a ball that breaks easily
50 to 75%	Appears dry; will not form a ball	Appears dry; will not form a ball
Less than 50%	Flows freely as single grains	Flows freely as single grains

FIGURE 8

TYPICAL INFILTRATION RATE CURVE

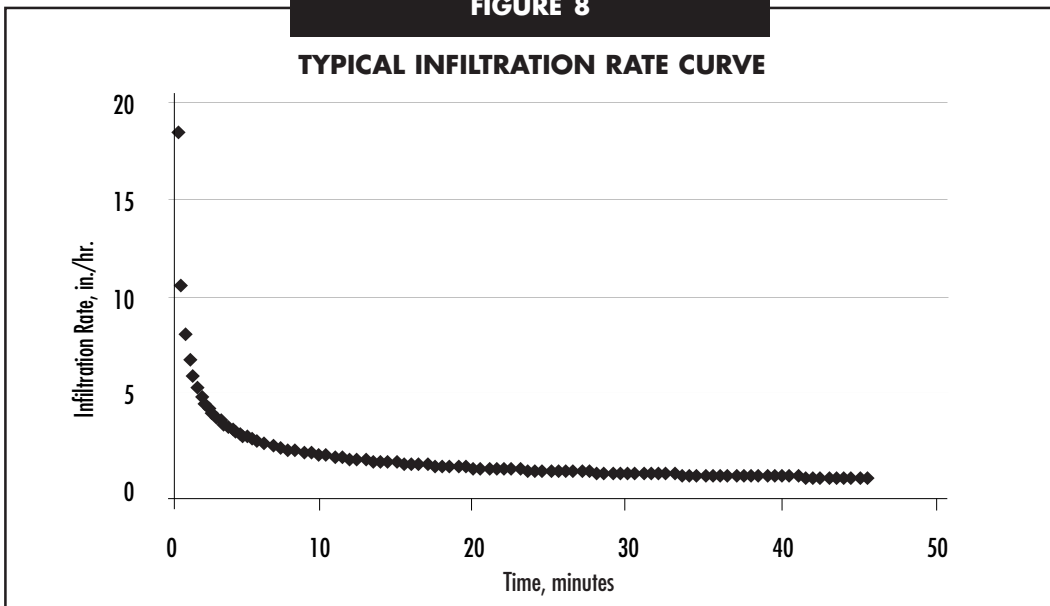

land application

TABLE 2*

**GENERAL FLOW RATES AND COVERAGE DIAMETER FOR
BIG GUN™ STATIONARY SPRINKLERS**

PRESSURE DIA. (FT.)	0.50		0.75		1.00		1.50		2.00	
	(PSI)	GPM	DIA. (FT.)	GPM	DIA. (FT.)	GPM	DIA. (FT.)	GPM	DIA. (FT.)	GPM
50	50	205	115	256	204	300	-	-	-	-
60	55	215	126	267	224	316	515	430	912	512
70	60	225	136	283	243	338	555	450	980	528
80	64	235	146	295	258	351	590	470	1047	548
90	68	245	155	306	274	362	625	485	1105	568
100	72	255	163	316	289	372	660	500	1167	592
110	76	265	171	324	304	380	695	515	1220	607

* Assumes gun is turning full circle.

FIGURE 9

TYPICAL LAYOUT OF A TRAVELING GUN IRRIGATION SYSTEM

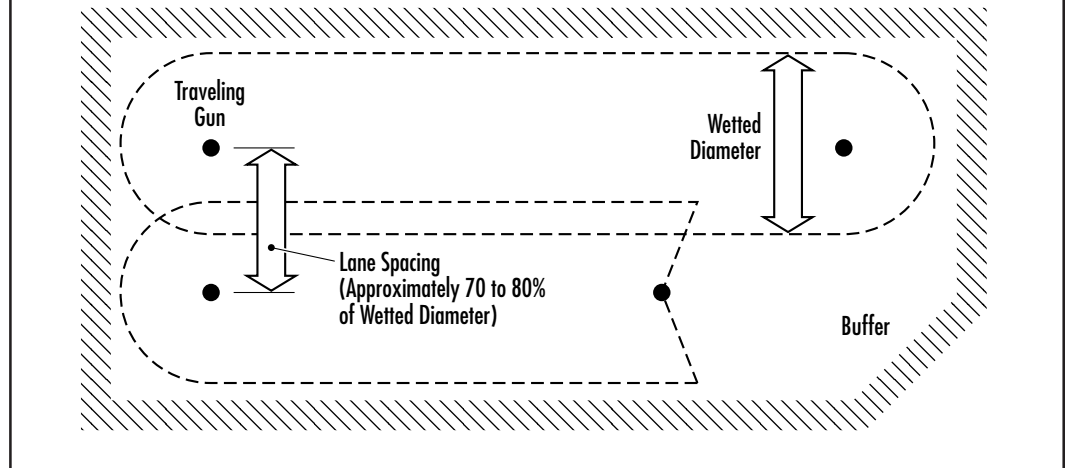

land application

TABLE 3

MANURE SPREADER CALIBRATION

MANURE SOURCE	KNOWN	MEASURE/CALCULATE	RESULT
Liquid manure in tank	1. Volume of manure tank in gallons	<u>Gallons</u>	Gallons per acre application rate
	2. Acreage over which manure is spread at even rate	<u>Acres</u>	
Liquid manure in spreader; volume method	1. Volume of manure spread in gallons	<u>Gallons x 43,560</u>	Gallons per acre application rate
	2. Distance driven and width spread, feet	<u>Distance x width</u>	
Liquid manure in spreader weight method	1. Pounds spread	<u>Pounds x 5,248</u>	Gallons per acre application rate (Assumes 62 pounds/cubic foot density)
	2. Distance driven and width spread, feet	<u>Distance x width</u>	
Solid manure in spreader; spreader volume method	1. Spreader struck-level volume, in bushels	<u>Bushels x 1,688</u>	Tons per acre application rate (Assumes 62 pounds/cubic foot density)
	2. Distance driven and width spread, feet	<u>Distance x width</u>	
Solid manure in spreader; plastic sheet weight method	1. Area of plastic sheet, in square feet	<u>Net weight, pounds x 21.78</u>	Tons per acre application rate
	2. Tare weight of manure on sheet after drive-over	<u>Area of plastic sheet, square feet</u>	
	Shortcut method:	<u>Net weight, pounds</u>	Tons per acre application rate
	Use 9 x 12 foot sheet	5	
	Shortcut Method:	<u>Net weight, pounds</u>	Tons per acre application rate

land application

TABLE 4

LIQUID MANURE APPLICATION RATES

		Distance of Travel, feet							
TANK SIZE (Gallons)	WIDTH OF Spread (ft.)	660	990	1320	1650	1980	2640	3900	5280
		GALLONS PER ACRE APPLIED							
1,000	10	6,600	4,400	3,300	2,640	2,200	1,650	1,117	825
	15	4,400	2,933	2,200	1,760	1,467	1,100	745	550
	25	2,640	1,760	1,320	1,056	880	660	447	330
1,500	10	9,900	6,600	4,950	3,960	3,300	2,475	1,675	1,238
	15	6,600	4,400	3,300	2,640	2,200	1,650	1,117	825
	25	3,960	2,640	1,980	1,584	1,320	990	670	495
2,000	10	13,200	8,800	6,600	5,280	4,400	3,300	2,234	1,650
	15	8,800	5,867	4,400	3,520	2,933	2,200	1,489	1,100
	25	5,280	3,520	2,640	2,112	1,760	1,320	894	660
2,400	10	15,840	10,560	7,920	6,336	5,280	3,960	2,681	1,980
	15	10,560	7,040	5,280	4,224	3,520	2,640	1,787	1,320
	25	6,336	4,224	3,168	2,534	2,112	1,584	1,072	792
2,800	10	18,480	12,320	9,240	7,392	6,160	4,620	3,127	2,310
	15	12,320	8,213	6,160	4,928	4,107	3,080	2,085	1,540
	25	7,392	4,928	3,696	2,957	2,464	1,848	1,251	924
3,000	10	19,800	13,200	9,900	7,920	6,600	4,950	3,351	2,475
	15	13,200	8,800	6,600	5,280	4,400	3,300	2,234	1,650
	25	7,920	5,280	3,960	3,168	2,640	1,980	1,340	990
3,200	10	21,120	14,080	10,560	8,448	7,040	5,280	3,574	2,640
	15	14,080	9,387	7,040	5,632	4,693	3,520	2,383	1,760
	25	8,448	5,632	4,224	3,379	2,816	2,112	1,430	1,056
3,600	10	23,760	15,840	11,880	9,504	7,920	5,940	4,021	2,970
	15	15,840	10,560	7,920	6,336	5,280	3,960	2,681	1,980
	25	9,504	6,336	4,752	3,802	3,168	2,376	1,608	1,188
4,000	10	26,400	17,600	13,200	10,560	8,800	6,600	4,468	3,300
	15	17,600	11,733	8,800	7,040	5,867	4,400	2,978	2,200
	25	10,560	7,040	5,280	4,224	3,520	2,640	1,787	1,320
4,200	10	27,720	18,480	13,860	11,088	9,240	6,930	4,691	3,465
	15	18,480	12,320	9,240	7,392	6,160	4,620	3,127	2,310
	25	11,088	7,392	5,544	4,435	3,696	2,772	1,876	1,386
4,800	10	31,680	21,120	15,840	12,672	10,560	7,920	5,361	3,960
	15	21,120	14,080	10,560	8,448	7,040	5,280	3,574	2,640
	25	12,672	8,448	6,336	5,069	4,224	3,168	2,144	1,584
5,000	10	33,000	22,000	16,500	13,200	11,000	8,250	5,585	4,125
	15	22,000	14,667	11,000	8,800	7,333	5,500	3,723	2,750
	25	13,200	8,800	6,600	5,280	4,400	3,300	2,234	1,650
6,000	10	39,600	26,400	19,800	15,840	13,200	9,900	6,702	4,950
	15	26,400	17,600	13,200	10,560	8,800	6,600	4,468	3,300

emergency action plans and safety



EMERGENCY ACTION PLANS

depend on the situation at the time.

Although not required by law, emergency action plans should be developed to meet current animal manure management regulations. Your plan can then be implemented in the event that manure from your operation is leaking, overflowing, or running off the site. You should NOT wait until manure reaches surface waters or leaves your property to consider that you have a problem. This plan should be available and understood by all employees at the facility because accidents, leaks, and breaks could happen at any time.

Emergency action plans must include provisions for emergency spreading or transfer of manure from all manure storage structures in the system. This may include emergency pumping or spreading (to prevent overtopping of a storage structure) during periods when the soil or crop conditions are not conducive to normal spreading or application. The Iowa Department of Natural Resources must be contacted for guidance in land-applying waste in this case. You should consider which fields are best able to handle the manure without further environmental or crop damage. Application rates, methods, and minimum buffer distances must be followed.

The main points of the emergency action plan, including the order of action and the relevant phone numbers, should be posted by all telephones at the site. A copy also should be available in remote locations or vehicles if the land application sites are not close by the facility office. It is the responsibility of the facility owner or manager to ensure that all employees understand what circumstances constitute an imminent danger to the environment or to the health and safety of workers and neighbors. Employees should be able to respond to such emergencies and notify the appropriate agencies of conditions at the facility.

Your plan should include these items: (1) stop the release of manure; (2) assess the extent of the spill and note any obvious damage; (3) contact the appropriate agencies (notification is required within six hours of an emergency); and (4) implement procedures to rectify the damage and repair the waste management system. The order in which they are accomplished will

1. Stop the release of manure.

Depending on the situation, this may or may not be possible. Suggested responses to several problems are listed below.

A. Lagoon or earthen basin release

Stop the release:

- Add soil to the berm to increase the elevation of the dam.
- Plug any line or valve at the basin that is leaking.
- Stop all additional flow to the structure (waterers, flushing system, surface runoff etc.).
- Ensure that no surface water is entering the storage structure.

Intercept the released liquid:

- Push up a small berm in the drainage way to stop overland flow.
- Plug tile outlets that are carrying contaminated liquid.

Prevent release from reaching water sources:

- Drive a pipe section down over tile risers, or pile soil around them.
- Pump waste to fields at an acceptable rate.
- Call a pumping contractor or neighbor with useful equipment if necessary.

B. Runoff from in-field manure application

- Immediately stop waste application.
- Create a temporary diversion or berm to contain the waste on the field.

emergency action plans and safety

- Incorporate waste to reduce further runoff.
- Evaluate and eliminate the reason(s) that caused the runoff.
- Evaluate the application rates for the fields where runoff occurred.

C. *Tile discharge*

- Stop application.
- Plug tile or tile inlets.

D. *Leakage from base or sidewall of lagoon or earthen storage structure (Often these are seepage rather than flowing leaks.)*

- Dig a small well or ditch to catch all seepage, put in a submersible pump, and pump the seepage back into the lagoon.
- If holes are caused by burrowing animals, trap or remove animals, fill the holes, and compact with a clay-type soil.
- Other holes may be likewise temporarily plugged with clay soil.

Note: Problems with lagoons and earthen storage structures require the consultation of an individual experienced in the design and installation of lagoons for permanent repair measures.

2. Assess the extent of the spill and note any obvious damage.

- Did the manure reach any surface waters?
- Approximately how much was released and for what duration?
- Did any damage such as employee injury, fish kills, or property damage occur?

- Did the spill leave the property?
- Does the spill have the potential to reach surface waters?
- Could a future rain event cause the spill to reach surface waters?

3. Contact appropriate agencies.

(Notification is required within six hours if a spill or hazardous event occurs. In some situations this may be the first action you should take.)

- During normal business hours, call your IDNR regional office. (See Chart 1 above.)
- Your phone call should include
 - Your name,
 - Facility,
 - Telephone number,
 - Details of the incident from item 2 (previous page),
 - Exact location of the facility,
 - Location or direction of the spill's movement,
 - Weather and wind conditions,
 - What corrective measures have been undertaken, and
 - The seriousness of the situation.

- 24-hour emergency response notification can be made to IDNR at **(515) 281-8694**. Both IDNR and local officials must be notified of spills or other releases.

- As a last resort, call 911 or the sheriff's department and explain your problem to them. Ask them to contact the appropriate agencies.

4. Implement procedures.

- Implement the procedures advised by the IDNR and technical assistance agencies to rectify the damage, repair the system. Reassess the emergency management

emergency action plans and safety

CHART 1

**FIELD OFFICE LOCATIONS
ENVIRONMENTAL PROTECTION DIVISION**

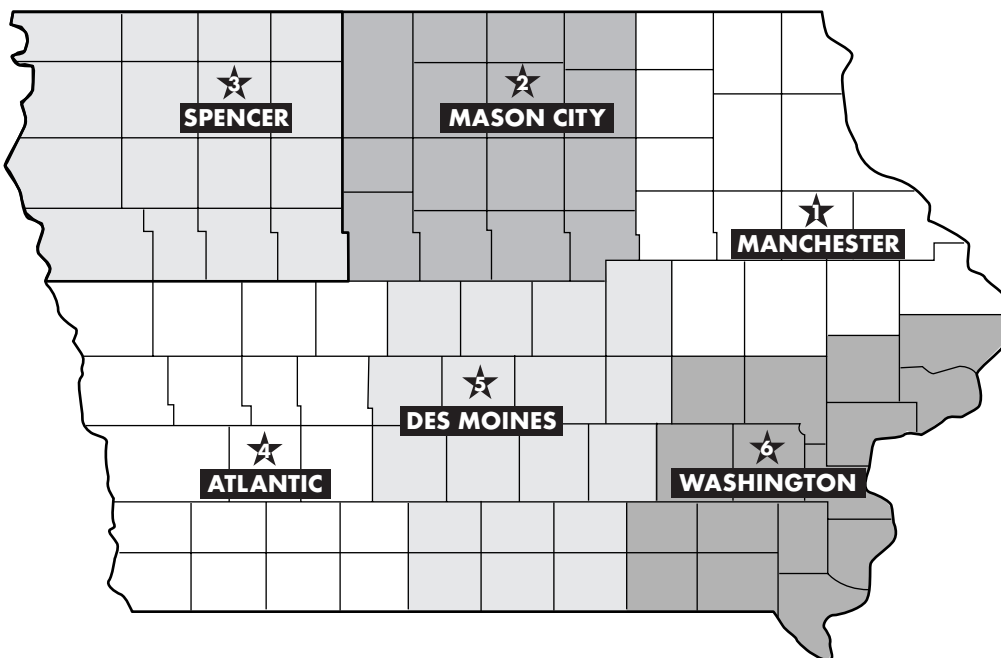

FIELD OFFICE	LOCATION	PHONE NUMBER	CONTACT
1	909 W. Main, Suite 4 • Manchester, IA 52057	319-927-2640	Jerry Rattenborg
2	2300 15th St. SW • Mason City, IA 50401	515-424-4073	William Jinkinson
3	1900 North Grand Ave. • Spencer IA 51301	712-262-4177	Barb Lynch
4	706 Sunnyside Lane • Atlantic, IA 50022	712-243-1934	Chuck Corell
5	607 E 2nd St. • Des Moines, IA 50309	515-281-9069	Jim Stricker
6	1004 West Madison • Washington, IA 52353	319-653-2135	Allan Goldberg

plan to prevent future problems with manure releases.

accident prevention.

PERSONAL SAFETY

Behind every accident is a chain of events that leads to an unsafe act, unsafe conditions, or a combination of both. Safety in the workplace should be everyone's concern. Communication between supervisors and employees generates ideas and safety awareness that leads to

Each year livestock producers, their employees, and their family members are injured in confinement livestock production. Manure storage structures and many livestock buildings are considered to be confined spaces.

emergency action plans and safety

There are three types of liquid manure storage structures, plus solid manure storage:

- Formed storage (deep pits and outside tanks)
- Lagoon systems
- Earthen slurry basins (holding ponds)
- Solid manure piles

Dangerous situations can be associated with the five main gases that are produced in livestock and poultry buildings and manure storage structures. These gases are listed in Table 1 (*see emergency and safety page 8*), along with some of their characteristics. All of these are colorless.

Manure Gases

Five gases are of primary concern with livestock facilities: ammonia, carbon dioxide, carbon monoxide, hydrogen sulfide, and methane. Hydrogen sulfide is especially dangerous during agitation and pumpout of enclosed pits. It can reach lethal concentrations and kill animals, both livestock and humans.

• Hydrogen sulfide

Hydrogen sulfide (H_2S) is the most toxic gas generated from liquid manure storage. Exposure to 200 ppm for an hour can cause headaches and dizziness; exposure to 500 ppm for 30 minutes can cause severe headaches, nausea, excitement, or insomnia. High concentrations of 800 to 1,000 ppm can cause immediate unconsciousness and death—from just a few breaths—through respiratory paralysis unless the victim is moved to fresh air and artificial respiration is immediately applied. Be aware—even the characteristic rotten-egg smell of hydrogen sulfide does not give adequate warning. The sense of smell is rapidly fatigued by the gas, and high concentrations do not give a proportionately higher odor intensity. Dangerous concentrations can be released by agitating stored liquid manure. Concentrations reaching 200 to 300 ppm have been reported in buildings a few minutes after starting to pump waste from a storage pit and can be as high as 800 ppm during vigorous

agitation.

• Methane

Methane (CH_4) is a product of manure decomposition under strict anaerobic conditions, such as those found in an anaerobic or biogas digester. It is insoluble in water and lighter than air; thus it will accumulate in stagnant air corners in the tops of enclosed, unvented pits or buildings. Methane is not toxic, but at high concentrations it may cause an asphyxiating environment. Methane concentrations in confinement housing normally are well below the levels that may be explosive (*See Table 1, emergency and safety page 8*). However, explosions attributed to methane have occurred around manure storage pits without proper vents.

First aid for victims of manure gas asphyxiation

1. **Do not** attempt to rescue a victim from a hazardous gas situation unless you are protected with a supplied-air breathing apparatus. Holding your breath is not an option.
2. Have someone telephone for an emergency medical rescue squad, informing them there is a “victim of toxic gas asphyxiation.”
3. If the victim is free from the immediate area of danger and there is no personal threat to life, do the ABC of first aid:
 - Airway check
 - Breathing check
 - Circulation check

If you are trained, do CPR or mouth-to-mouth if necessary.

Training courses for rescue breathing and CPR are available through your local Red Cross chapter.

Effect of air quality on human health

emergency action plans and safety

Health problems associated with poor air quality include coughing, phlegm production, wheezing, chest tightness, headaches, shortness of breath, eye irritation, sneezing, runny nose, and nasal congestion. Problems usually are greater the more time a worker spends in the presence of the contaminant and the higher the concentrations of airborne contaminants. In addition, some people are more susceptible than others.

Health problems may be chronic (lasting a long time) or acute (severe but short term). Since chronic and acute problems can be mistaken for other health problems, such as the flu or allergies, the work environment often is overlooked as a cause of the symptoms, so precautions are not taken. Table 2 (*see emergencies and safety page 8*) lists some symptoms swine facility workers in Iowa have experienced as the result of poor air quality in swine buildings.

You should consider the following safety points when constructing, operating, and managing animal manure management systems:

- Do not enter a manure pit unless following specific procedures for entering a confined space.
- When agitating a manure storage structure, always have at least one additional person available to seek help if trouble occurs.
- Use properly designed and operated ventilation systems to reduce the concentration of gases within buildings.
- When possible, construct lids for manure pits and tanks and keep them in place. If an open, ground-level tank or pit is necessary, build a fence around it and post with **Keep Out** and **Danger: Manure Storage** signs.
- Get help before attempting to rescue livestock or people that have fallen into

a manure storage structure.

- Build railings along all walkways or piers of open manure storage structures.
- Place locked entry guards on permanent ladders on the outside of above-ground tanks unless the ladders cannot be reached from the ground. Never leave a ladder standing against an above-ground tank.
- Construct permanent ladders on the inside wall of all pits and tanks, even if covered. Use non-corrosive material to prevent deterioration of the ladders.
- Fence in earthen storage basins and lagoons, and erect signs: **Danger: Manure Storage**. Additional precautions include a minimum of one lifesaving station equipped with a reaching pole and a ring buoy on a line.
- Place barriers strong enough to stop a slow-moving tractor on all push-off platforms.
- If possible, remove animals from buildings before agitating manure stored in in-house pits. Otherwise:
 - If the building is mechanically ventilated, turn fans on full capacity before starting agitation, or
 - If the building is naturally ventilated, do not agitate unless there is a brisk breeze. Watch animals closely when beginning to agitate, and turn off the pump at the first sign of trouble.
- If the manure storage is outside the livestock building, use a water trap or other device to prevent gases from entering the building.
- During agitation, if an animal becomes affected by toxic gases, do not try to rescue it; you could become the victim. Turn off the agitation pump, ventilate the building, and do not enter the building until gases have had a chance to escape.
- Do not smoke, weld, or use an open flame

emergency action plans and safety

in confined, poorly ventilated areas where methane can accumulate. Use only explosion proof electric motors, fixtures, and wiring near manure storage structures to prevent a spark from igniting the methane.

- Keep all guards and safety shields on all mechanical equipment.

SUMMARY OF KEY POINTS

- There are two primary safety concerns in manure storage and handling: environmental safety and personal safety.
- Every livestock facility should have an environmental emergency action plan available to all employees.
- Emergency action plans should include
 - A plan to stop potential uncontrolled releases of manure,
 - Phone numbers of those who can help stop any release,
 - Notification plan including agency phone numbers,
 - A cleanup plan.
- Notification of IDNR field or state office and local law enforcement officials is required in the event of a spill or other release.
- If runoff results during manure application, stop applying immediately.

- Ammonia,
- Methane,
- Hydrogen sulfide,
- Carbon monoxide, and
- Carbon dioxide.

- Hydrogen sulfide is the most dangerous of these gases. At high concentrations it can kill with just a few breaths.
- Always use maximum ventilation during agitation and pumping from deep pits.
- If one or more animals go down during agitation and pumpout, shut off the pumps but do not try to rescue the animals immediately.
- Poor air quality in livestock facilities can cause long-term illness.

- The five main gases produced by animal facilities are

emergency action plans and safety

emergency action plans and safety

TABLE 1

CHARACTERISTICS AND EFFECTS OF GASES PRODUCED IN LIVESTOCK BUILDINGS AND MANURE STORAGE STRUCTURES

GAS	ODOR	DENSITY	HEALTH EFFECTS
Ammonia (NH ₃)	Pungent	Lighter than air	Irritation to eyes and nose. Asphyxiating at high levels.
Carbon dioxide (CO ₂)	None	Heavier than air	Drowsiness, headache. Can be asphyxiating.
Carbon monoxide (CO)	None	Lighter than air	Headache, chest pains, potential for problems with developing fetuses. Can be asphyxiating.
Hydrogen sulfide (H ₂ S)	Rotten-egg smell	Heavier than air	TOXIC: causes headache, dizziness, nausea, unconsciousness, death.
Methane (CH ₄)	None	Lighter than air	Headache, asphyxiating, explosive 5 to 15 percent

TABLE 2

HEALTH SYMPTOMS OF IOWA SWINE FACILITY WORKERS

SYMPTOM	PREVALENCE (PERCENT)
Cough	67
Sputum or phlegm	56
Scratchy throat	54
Runny nose	45
Burning or watery eyes	39
Headaches	37
Chest tightness	36
Shortness of breath	30
Wheezing	27



applicator rules

In 1998 the Iowa legislature passed House File 2494, which regulates animal feeding operations. The Iowa Department of Natural Resources (IDNR) enforces the law. The main body of this law is included in the Environmental Section of the Iowa Administrative Rules (chapter 65). While chapter 65 addresses all animal feeding operations, the more recent regulations pertain only to “confined animal feeding operations” (CAFOs)—those animal feeding operations in which animals are confined to totally roofed areas.

MANURE APPLICATOR CERTIFICATION

The 1998 law mandates that manure applicators must be certified. There are two classifications of manure applicators: commercial applicators and confinement site applicators. Commercial applicators are those who apply manure for others for a fee. Confinement site applicators are livestock producers who operate a confinement facility other than a small animal feeding operation (SAFO; less than 200,000 lbs. of bodyweight for swine and poultry or less than 400,000 lbs. for bovine) and apply their own manure. Employees and others involved in applying manure from other than SAFO’s must also be certified unless they are under the direct supervision of a certified applicator who can physically observe and communicate with the worker at all times.

The type of manure (liquid or dry) makes no difference, only the size of operation is considered. Essentially, confinement operators who need manure management plans and apply their own manure must be certified. Confinement operators who have commercial applicators apply their manure do not need to be certified.

Each year commercial applicators must pass a test OR receive three hours of continuing education. Site applicators must pass a test every three years OR receive two hours of continuing education each year.

MANURE MANAGEMENT PLANS

Manure management plans formally outline where the manure from a livestock operation will be applied. Confinement operations built or expanded since May 31, 1985 and exceeding the following sizes are required to file a manure

management plan with the IDNR:

- Swine and poultry operations exceeding 200,000 lbs.
- Beef and dairy systems exceeding 400,000 lbs.

The law does not apply open feedlots. It applies only to operations using total confinement (confinement operation house animals in totally roofed facilities). Other than small animal feeding operations are also exempt. Tables 1–3 (*see applicator rule page 10*) give animal capacity estimates for various weight categories larger than SAFOs.

A manure management plan is a legal document developed by the producer. The plan must outline how manure from the operation will be applied so that it does not cause pollution. In addition to defining the amount of manure that will be applied, it defines

- The owner and name of the confinement feeding operation, including the mailing address and phone number.
- The contact person for the confinement feeding operation, including the mailing address and phone number.
- Animal weight capacity.
- Location of confinement feeding operation (indicated on the plat map) and estimate of annual animal production and manure volume or weight produced.

This should include the legal description of the site and an estimate of the animal production.

applicator rules

Example:

The confinement building is located in the NW 1/4 of the NW 1/4 of section 27 T91N-R36W.

The building holds 1,000 head of finishing pigs. Manure production estimate is 1.2 gals./head/day.

Estimate of annual animal production =
 1,000 head x 2.7 turns/year = 2,700 head per year

Estimate of annual manure production =
 1.2 gals./head/day x 1,000 head x 345 days/year = 414,000 gals./year

- Total nitrogen available for application from the confinement operation.

Example:

Calculate the total N available from a 2,000-head finishing operation. To do so, multiply the pounds of N produced each year from a space in the building (21 lbs.) by the number of spaces (or head raised at one time).

21 lbs. N/space x 2,000 head =
 42,000 lbs. N

- The optimum yield and usage rate for the crops indicated in the crop schedule.

The optimum crop yield can be determined by calculating the average yield for all but the lowest crop yield for the period of the crop schedule, or by calculating the average for all years and adding 10 percent.

Records that can be used to determine optimum crop yields are

- Soil survey interpretation records: use data on soil types from the Natural Resource Conservation Service to determine a weighted average yield for field.
- Consolidated Farm Service Agency yields
- County-wide crop insurance yields
- Multiperil crop insurance proven yields: the optimum yield determined for each crop shall be the average of at least three years of yield data.
- County average yields from USDA Agricultural Statistics Service.
- Proven yields. These can be used only if a minimum of the most recent three years of yield data is submitted on a field-by-field or farm-by-farm basis. Years with crop disasters may be excluded from the calculations.

Example:

A 156-acre farm is split into two 78-acre fields, using multiperil crop insurance proven yields.

<u>Year</u>	<u>Reported yield, corn</u>
1994	164
1995	139
1996	148
1997	152
1998	156
Total	759

Average=759/5=151.8

Adding 10 percent = 151.8 +
 (151.8)(.10) = 167 bu./acre

- Crop schedule: a listing of the crops to be planted on fields used for manure applications for the current and successive years.

Example:

applicator rules

Year	Crop
1999	Corn
2000	Soybeans
2001	Corn
2002	Soybeans
2003	Corn
2004	Soybeans

- Crop usage rates: crop nitrogen requirements based on Table 4 (*see applicator rules page 11*) or other credible sources.

Example:

The corn usage rate for Boone County is 1.2 lbs. N/bushel; the soybean usage rate is 3.8 lbs./bushel. (*Figures taken from Table 4.*)

When utilizing the N usage rate factors from Table 4 (or other credible source) to calculate the amount of land needed for manure application, you must account for additional N that is applied to the soil and reduce the amount of manure that can be applied accordingly. This includes liquid nitrogen that is applied with the herbicide. The only provision for applying additional N after applying a full rate of manure is to take a late spring soil nitrate test or plant tissue test and follow the recommendations.

- Manure application methods and timing of the application.

Identify the methods that will be used to apply manure to the land and the time of the year it will be applied (either by season or month).

Example:

The manure will be knifed into the crop residue in the fall (or spring).

- Calculations to determine the land area required for manure application.

Example:

Determine the land area requirement based on N for a 1,000-head swine finishing facility in Boone County. To do so, estimate the amount of land required for manure application by dividing the total N available by the estimated crop usage rate factor for the area. Available N is 21 pounds per finish space. The desired corn yield is 150 bushels/ acre following a 50-bushel/acre soybean crop. The crop yield factor for corn for Boone County is 1.2.

$$\begin{aligned} \text{Total N available} &= 1,000 \text{ head} \\ &\quad \times 21 \text{ lbs./space} \\ &= 21,000 \text{ lbs. N} \end{aligned}$$

$$\begin{aligned} \text{Estimated N need} &= 150 \text{ bu. corn} \times 1.2 \\ &= 180 \\ &\quad - 50 \text{ soybean credit} \\ &= 130 \text{ lbs. N/acre} \end{aligned}$$

$$\begin{aligned} \text{Land required} \\ \text{for manure} \\ \text{application} &= (21,000 \text{ lbs. N}) / \\ &\quad (130 \text{ lbs. N/acre}) \\ &= 162 \text{ acres} \end{aligned}$$

- Location of manure application area(s).

The plan shall identify each farm where the manure is to be applied, the number of available acres for application, and under what basis the land is available. This should include the legal description and a map.

The basis for crop production includes owning the land, renting the land, or a written agreement. If the land is available through a written agreement, a copy of the agreement should be included in the plan.

If the land available for manure application changes over time, the current plan must contain the proper documentation of land for manure application before the next application period.

Example:

applicator rules

Field 1, NE 1/4 section 28 T91N-R36W
142 acres of tillable land rented from
John Doe

- Methods, structures or practices that will be used to reduce soil loss and potential surface water pollution.

The manure management plan shall include a copy of the conservation plan if the manure will be applied on highly erodible cropland.

Example:

All land in this manure management plan is not highly erodible. The manure will be knifed into the soil on the contour to minimize soil loss and potential surface water contamination. Residue cover will be maintained in accordance with my conservation plan.

- Method or practices that will be used to reduce odor if spray irrigation equipment is used to apply manure.

Example:

The irrigation system will use a low-pressure system that directs the manure application downward. The manure application will occur only when the wind is from the north or west, which will carry the odor away from the nearest neighbor (located 1,500 feet away from the application area).

The completed plan should include a cover letter written by the contact person explaining his or her understanding of the plan and its implementation. It should state that the producer will follow the plan. A copy of the plan and the indemnity fee (if required) should be mailed to:

Iowa Department of Natural Resources
Environmental Protection Division
Wallace State Office Building
900 East Grand Ave.

Des Moines, IA 50319-0034

RECORDS

The animal feeding operation must maintain records that include the current manure management plan and the date, location, rate, and method of each manure application, including the number of acres to which manure was applied.

The plan may, but is not required to, be updated with manure test results and additional calculations when other land becomes available. These documents must be added to the plan prior to each year's application. Records must be maintained in the producer's file to show compliance with the plan. The date and signature of the record keeper should appear on each document.

The IDNR may inspect the records during normal business hours to ensure compliance.

MANURE APPLICATION SEPARATION DISTANCES AND RESTRICTIONS

The separation distance for surface-applied liquid manure that is not incorporated within 24 hours is 750 feet from a nonowner residence, commercial enterprise, bona fide religious institution (church), educational institution, or public use area, including cemeteries. Small animal feeding operations (SAFOs) and operations using dry forms of manure are exempt from this regulation, and neighbors can grant waivers.

Designated areas are defined as known sinkholes, cisterns, abandoned wells, unplugged agricultural drainage wells, agricultural drainage well surface tile inlets, drinking water wells, or privately owned lakes or farm ponds. Designated areas

applicator rules

do not include terrace tile inlets or surface tile inlets other than agricultural drainage well inlets. Manure shall not be applied within 200 feet of a designated area unless it is incorporated within 24 hours or injected; if permanent vegetative cover exists for 50 feet surrounding the designated area, however, manure can be applied up to that vegetative cover.

The minimum separation distance for spray irrigation is 100 feet from the wetted perimeter to the property line or right-of-way. However, other separation distances may apply, depending on the manure source and the type of irrigation system used. Required distances are greatest for slurry manure applied through a high-pressure system and least for anaerobic lagoon effluent applied through a low-pressure, downward projecting system (*see Table 5, applicator rules page 11*).

The following practices are not mandatory, but are recommended:

- Manure application should not occur on land areas located within 200 feet of and draining into a stream or surface intake for a tile line if surface-applied manure is not incorporated within 24 hours. If the surface inlet drains into an agricultural drainage well, the recommended separation distance for spreading is increased to 500 feet.
- Manure application on frozen or snow-covered ground should be avoided if possible. If manure is applied on frozen or snow-covered ground, it should be restricted to slopes of 4 percent or less where adequate erosion control practices exist.
- Manure application on cropland subject to flooding more than one year in 10 should be incorporated or knifed in within 24 hours.
- On cropland with a slope of more than 10 percent, manure should be applied only where adequate erosion control measures exist.

ADJACENCY AND BUILDING SEPARATION DISTANCES

Two or more sites under common ownership are adjacent to each other and considered to be one site if they are closer than the distances shown in Table 6 (*see applicator rules page 11*).

Separation distances

There are separation distances are the distances between a feeding operation structure (buildings, pits, lagoons, etc.) and neighboring residences, businesses, or public areas. Note that the distance is measured from the actual structures, not from the property lines. The separation distances are based on the type of manure storage and the one-time animal weight capacity (*see Tables 7 and 8, applicator rules pages 12 and 13*). Exemptions to these separation distances are granted if

- The operation is a SAFO.
- The operation uses exclusively dry manure.
- The neighbor signs a written waiver and it is recorded at the courthouse;
- An existing operation expands away from the neighboring residence, and the expansion does not result in a new operation that has more than doubled in capacity since May 1995 or exceeds 625,000 pounds, whichever is less; or
- An existing feeding confinement operation was established prior to the neighboring residence.

Animal feeding operation formed structures cannot be located within 500 feet of agricultural drainage wells, known sinkholes, or agricultural drainage well surface intakes. Structures also must be 100 to 1,000 feet from wells, depending

applicator rules

on the type of structure and type of well, as shown in Tables 7 and 8 (*see Tables 7 and 8, applicator rules pages 12 and 13*).

Right-of-way separation distance

All new animal feeding buildings or manure holding structures shall be built at least 100 feet from the road right-of-way. This separation distance may be reduced if trees are planted between the right-of-way and the building in accordance with IDNR rules, or if the county provides a waiver.

Water course separation distances

All new animal feeding buildings or manure holding structures shall be built at least 200 feet away from a water source with a bed and banks; and 500 feet from a water course that is considered to be navigable, an agricultural drainage well, or the surface intake to an agricultural drainage well.

CONFINEMENT ANIMAL FEEDING OPERATION CONSTRUCTION PERMITS

Construction permits are required for new or expanded confinement operations that exceed the sizes indicated in Table 9 (*see applicator rules page 14*).

A registered professional engineer must submit the design plans to the IDNR as part of the permit application. The application includes the manure management plan, soil siting information, building designs and specifications,

and the indemnity fee. The IDNR has 60 days to approve or deny the request once a completed application has been submitted.

A copy of the application also will be given to the county board of supervisors (CBOS), which will publish a notice in the newspaper. The newspaper notice shall include

- The name of person seeking the construction permit,
- The name of township where operation will be built,
- The structures to be built,
- The animal weight capacity,
- The time and place where the public may examine application, and
- The procedures for proving public comment to the board of supervisors.

The CBOS may hold a public hearing to receive comments. Appropriate comments would include

- Objects that should have separation distance requirements that are not in the report,
- Suitability of soils and hydrology on the proposed site,
- Land availability for manure application, and
- Whether new construction will impede drainage.

The IDNR shall notify the CBOS at least three days before conducting a site inspection; the CBOS may send a designee to attend the site inspection.

The IDNR shall consider and respond to comments submitted by the county board of supervisors (CBOS) within 30 days of receiving

applicator rules

the completed application. The IDNR must notify the CBOS within three days of their decision to approve or disapprove the application. If the CBOS disagrees with IDNR, they can contest the decision to the Environmental Protection commission within 14 days of receiving the decision from the IDNR. The commission must act within 35 days of receiving the paperwork from the CBOS. The decision of the commission shall be final.

prior to manure application but do not need to be filed with the IDNR.

- Separation distance from neighbors for broadcast liquid manure is 750 feet unless it is incorporated within 24 hours.
- Separation distance from designated areas is 200 feet for broadcast manure that is not injected.
- Designated areas are wells, abandoned wells, agricultural drainage wells, and agricultural drainage cisterns, sinkholes, farm ponds or private lakes.
- The law defines separation distances for structures from a water source (a small stream) and a water course (a navigable stream) as 200 and 500 feet, respectively.
- Separation distances between animal facilities and neighbors depend primarily on the species, size of operation, and type of manure storage.
- Separation distances are between the animal structure and the neighboring residence, not between the animal structure and the neighbor's property line.
- Adjacency distances are used to determine whether multiple buildings are one or more operations.
- The base adjacency distance for livestock operations is 1,250 feet.
- The indemnity fund fee for new or expanding facilities was doubled by the new law.

SUMMARY OF KEY POINTS

- Chapter 65 of the Iowa Administrative Code contains confined animal feeding regulations. The IDNR enforces the regulations.
- Manure management plans are required of swine or poultry producers with more than 200,000 pounds of animal weight capacity facility at any one time.
- Manure management plans are required of beef or dairy producers with more than 400,000 pounds of animal weight capacity.
- The general information needed for manure management plans includes the owner/operator's name, the amount of manure produced, and the number of acres on which it will be spread.
- Manure management plans can be based on nitrogen. All sources of nitrogen must be accounted for in the manure plan and the total N applied cannot exceed plant requirements.
- There are several different sources of yield information for manure plans.
- Manure plans must be kept up to date in the producer's file. Updates must be made

applicator rules

applicator rules

applicator rules

TABLE 1

FACILITY WEIGHT CAPACITY FOR SWINE

----- Number of animals-----

AVERAGE CAPACITY	SOWS (400 lbs.)	NURSERY (25 lbs.)	MARKET HOGS (150 lbs.)	FARROW TO FINISH (10 pigs per litter)
200,000 lbs.	500	8,000	1,333	105 sows
625,000 lbs.	1,563	25,000	4,167	329 sows
1,250,000 lbs.	3,125	50,000	8,333	658 sows

TABLE 2

FACILITY WEIGHT CAPACITY FOR BOVINE

----- Number of animals-----

AVERAGE CAPACITY	SLAUGHTER CATTLE (750 lbs.)	FEEDER CATTLE (625 lbs.)	DAIRY (1,500 lbs.)
400,000 lbs.	533	640	267
1,600,000 lbs.	2,133	2,560	1,067
4,000,000 lbs.	5,333	6,400	2,667

TABLE 3

FACILITY WEIGHT CAPACITY FOR POULTRY

----- Number of animals-----

AVERAGE CAPACITY	LAYING HENS (4 lbs.)	BROILERS (2 lbs.)	TURKEYS (10 lbs.)
200,000 lbs.	50,000	100,000	20,000
625,000 lbs.	156,250	312,500	62,500
1,250,000 lbs.	312,500	625,000	125,000

applicator rules

TABLE 4

CROP NITROGEN USAGE RATE FACTOR

CROP	NITROGEN USAGE
Corn Zone 1 ^a	0.9 lbs./bu.
Corn Zone 2 ^b	1.1 lbs./bu.
Corn Zone 3 ^c	1.2 lbs./bu.
Corn silage	7.5 lbs./ton
Soybeans	3.8 lbs./bu.
Oats	0.75 lbs./bu.
Alfalfa	50.0 lbs./ton
Wheat	1.3 lbs./bu.
Smooth brome	40.0 lbs./ton
Sorghum or Sudan grass	40.0 lbs./ton

^a Zone 1 corresponds to the Moody soil association.

^b Zone 2 corresponds to the Marshall, Monona-Ida-Hamburg, and Galva-Primghar-Sac soil associations.

^c Zone 3 corresponds to the remaining soil associations.

TABLE 5

REQUIRED SEPARATION DISTANCE (FOR SPRAY IRRIGATION) FROM ACTUAL WETTED PERIMETER TO RESIDENCE, COMMERCIAL ENTERPRISE, RELIGIOUS INSTITUTION, EDUCATIONAL INSTITUTION, OR PUBLIC USE AREA

MANURE SOURCE	HIGH PRESSURE	LESS THAN 20 PSI LOW PRESSURE CENTER PIVOT DIRECTED DOWNWARD
Earthen manure basin, formed manure storage structure*	1,000 feet	250 feet
First or second stage anaerobic lagoon	750 feet	250 feet
Third stage anaerobic lagoon	750 feet	250 feet
Aerobic lagoon	750 feet	250 feet

* With high pressure and earthen basin or fored, need 15:1 dilution.

TABLE 6

MINIMUM DISTANCE REQUIREMENT WHICH ALLOWS TWO SITES TO BE CONSIDERED AS SEPARATE OPERATIONS

FACILITY CAPACITY	LBS. BODYWEIGHT	DISTANCE, FEET
Swine, poultry, and others	<625,000	1,250
	≥625,000	2,500
Bovine	<1,600,000	1,250
	≥1,600,000	2,500

applicator rules

TABLE 7

SEPARATION DISTANCE REQUIREMENTS FOR STRUCTURES FOR NON-BOVINE OPERATIONS (SWINE, SHEEP, HORSES, AND POULTRY)

TYPE OF STRUCTURES	SIZE OF OPERATION, ANIMAL WEIGHT	Residences, ^a commercial enterprises, --- religious institutions, or educational institutions ---		
		UNINCORPORATED AREA	INCORPORATED AREA	PUBLIC USE AREA
	CAPACITY	(IN FEET)	(IN FEET)	(IN FEET)
Anaerobic lagoons and uncovered earthen manure storage basins	<625,000 lbs.	1,250	1,250	1,250
	625,000 lbs. to <1,250,000 lbs.	1,875	1,875	1,875
Covered earthen manure storage basins	1,250,000 lbs. or more	2,500	2,500	2,500
	<625,000 lbs.	1,000	1,250	1,250
Uncovered formed manure storage structures	625,000 lbs. to <1,250,000 lbs.	1,250	1,875	1,875
	1,250,000 lbs. or more	1,875	2,500	2,500
Confinement buildings, covered formed manure storage structures	<200,000 lbs.	None	None	None
	200,000 lbs. to <625,000 lbs.	1,000	1,250	1,250
	625,000 lbs. to <1,250,000 lbs.	1,250	1,875	1,875
	1,250,000 lbs. or more	1,875	2,500	2,500
Egg washwater storage structures	<200,000 lbs.	None	None	None
	200,000 lbs. to <625,000 lbs.	750	1,250	1,250
	625,000 lbs. to <1,250,000 lbs.	1,000	1,875	1,875
	1,250,000 lbs. or more	1,500	2,500	2,500
	PRIVATE SHALLOW WELL	PRIVATE DEEP WELL	PUBLIC SHALLOW WELL	PUBLIC DEEP WELL
Anaerobic lagoons, aerobic structures, earthen manure storage basins, or runoff control basins	400	400	1,000	400
Confinement buildings,				

applicator rules

TABLE 8

SEPARATION DISTANCE REQUIREMENTS FOR STRUCTURES FOR BOVINE OPERATIONS (BEEF AND DAIRY)

TYPE OF STRUCTURES	SIZE OF OPERATION, ANIMAL WEIGHT	Residences, ^a commercial enterprises, --- religious institutions, or educational institutions ---		PUBLIC USE AREA	
		UNINCORPORATED AREA	INCORPORATED AREA		
	CAPACITY	(IN FEET)	(IN FEET)	(IN FEET)	
Anaerobic lagoons and uncovered earthen manure storage basins	<1,600,000 lbs.	1,250	1,250	1,250	
	625,000 lbs. to <1,250,000 lbs.	1,875	1,875	1,875	
Covered earthen manure storage basins	1,250,000 lbs. or more	2,500	2,500	2,500	
	<1,600,000 lbs.	1,000	1,250	1,250	
Covered earthen manure storage basins	625,000 lbs. to <1,250,000 lbs.	1,250	1,875	1,875	
	1,250,000 lbs. or more	1,875	2,500	2,500	
Uncovered formed manure storage structures	<400,000 lbs.	None	None	None	
	<1,600,000 lbs.	1,250	1,250	1,250	
	1,600,000 lbs. to <4,000,000 lbs.	1,500	1,875	1,875	
Confinement buildings, covered formed manure storage structures	4,000,000 lbs. or more	2,000	2,500	2,500	
	<400,000 lbs.	None	None	None	
	<1,600,000 lbs.	1,000	1,250	1,250	
	1,600,000 lbs. to <4,000,000 lbs.	1,250	1,875	1,875	
Egg washwater storage structures	4,000,000 lbs. or more	1,875	2,500	2,500	
	<200,000 lbs.	None	None	None	
	200,000 lbs. to <625,000 lbs.	750	1,250	1,250	
Egg washwater storage structures	625,000 lbs. to <1,250,000 lbs.	1,000	1,875	1,875	
	1,250,000 lbs. or more	1,500	2,500	2,500	
		PRIVATE SHALLOW WELL	PRIVATE DEEP WELL	PUBLIC SHALLOW WELL	PUBLIC DEEP WELL
Anaerobic lagoons, aerobic structures, earthen manure storage basins, or runoff control basins	400	400	1,000	400	
Confinement buildings, formed manure storage					

applicator rules

TABLE 9

MINIMUM THRESHOLDS FOR CONSTRUCTION PERMITS

TYPE OF STRUCTURE USED BY OPERATION	----- Operation Size -----	
	SWINE, POULTRY AND OTHERS	BEEF AND DAIRY
Lagoons	>200,000 lbs.	>200,000 lbs.
Earthen manure structure	>200,000 lbs.	>400,000 lbs.
Formed manure structure	>625,000 lbs.	>1,600,000 lbs.

TABLE 10

**INDEMNITY FEES CHARGED TO PRODUCERS WHO FILE
MANURE MANAGEMENT PLANS AFTER 1/1/99.**

----- Fees based on size of operation, \$/100 head capacity -----

CONFINEMENT BUILDING TYPE	----- Fees based on size of operation, \$/100 head capacity -----		
	<625,000 LBS.	>625,000 LBS. TO <1,250,000 LBS.	1,250,000 LBS. OR MORE
Slaughter or feeder cattle	\$10.00	\$15.00	\$20.00
Dairy cattle	\$14.00	\$21.00	\$28.00
Butcher or breeding swine over 55 lbs.	\$ 4.00	\$ 6.00	\$ 8.00



record keeping

Record keeping is important for a variety of reasons:

- To ensure that the manure management plan is being followed,
- To enhance our ability to remember past actions,
- To help make management decisions, and
- To ensure regulators that the operation is not violating any state or federal laws.

Good records are easy to keep and will provide the information you need without collecting any extraneous information. For confinement operations with manure management plans. IDNR rules require records to be kept. They must be made available to IDNR for inspection upon demand.

NITROGEN RECORDS

Most manure management plans are based on nitrogen balance because nitrogen is the main manure nutrient with known environmental concerns. Excessive applications of nitrogen from any source adversely affect groundwater. On the other hand, plants deficient in nitrogen produce lower yields. Using the available technology to control nitrogen application will prevent both extremes.

The plan for new buildings is based on book values for manure nutrients or similar historical records. University studies have shown that the nutrient content of manure varies greatly during the start-up year, depending on weather conditions and how much water is added to the pit.

After the building is used for several years, the nutrient content tends to stabilize, unless there is a problem such as a broken water line. A good representative manure test for nutrient content provides the necessary documentation to adjust the application rate for an individual storage unit.

The law allows application of additional nitrogen if late spring soil nitrate tests are performed or plant tissue testing is conducted. Additional

nitrogen may be applied up to the recommended level indicated by the test results. These test records should be kept in the manure plan to document this decision.

LAND APPLICATION RECORDS

The law requires that applicators record the date, field location, manure application rate, and acres covered for each land application. The signature of the person recording the information adds credibility to the record.

Weather conditions also are important records; they affect certain spreading results and are hard to remember. For example, wind direction and velocity during spreading can influence where an odor plume will travel. Furthermore, weather conditions change over short periods of time, so the more frequently they are recorded, the more accurate the record will be.

FIELD SKETCHES

A sketch of the field and pertinent land features can also be a useful part of the record. It can help explain problems such as nitrogen deficiency or compaction and can be used to determine the measures needed to correct them. Your field sketch should include

- A north arrow,
- The shape of the field,
- Residence houses,
- Landscape features such as wells, rivers, lakes, and surface intakes that require surface manure application separation distances,

record keeping

- The spread pattern (up and down rows, across, or diagonal), and
- The location of the field gate.

SAMPLE RECORDS

The following (*record keeping pages 3-8*) are examples of records forms that can be used to show compliance with a manure management plan. The data provided is for demonstration only. Note that the field sketch form has been left blank.

record keeping

FIELD SKETCHES

FIELD _____ **CROP YEAR** _____

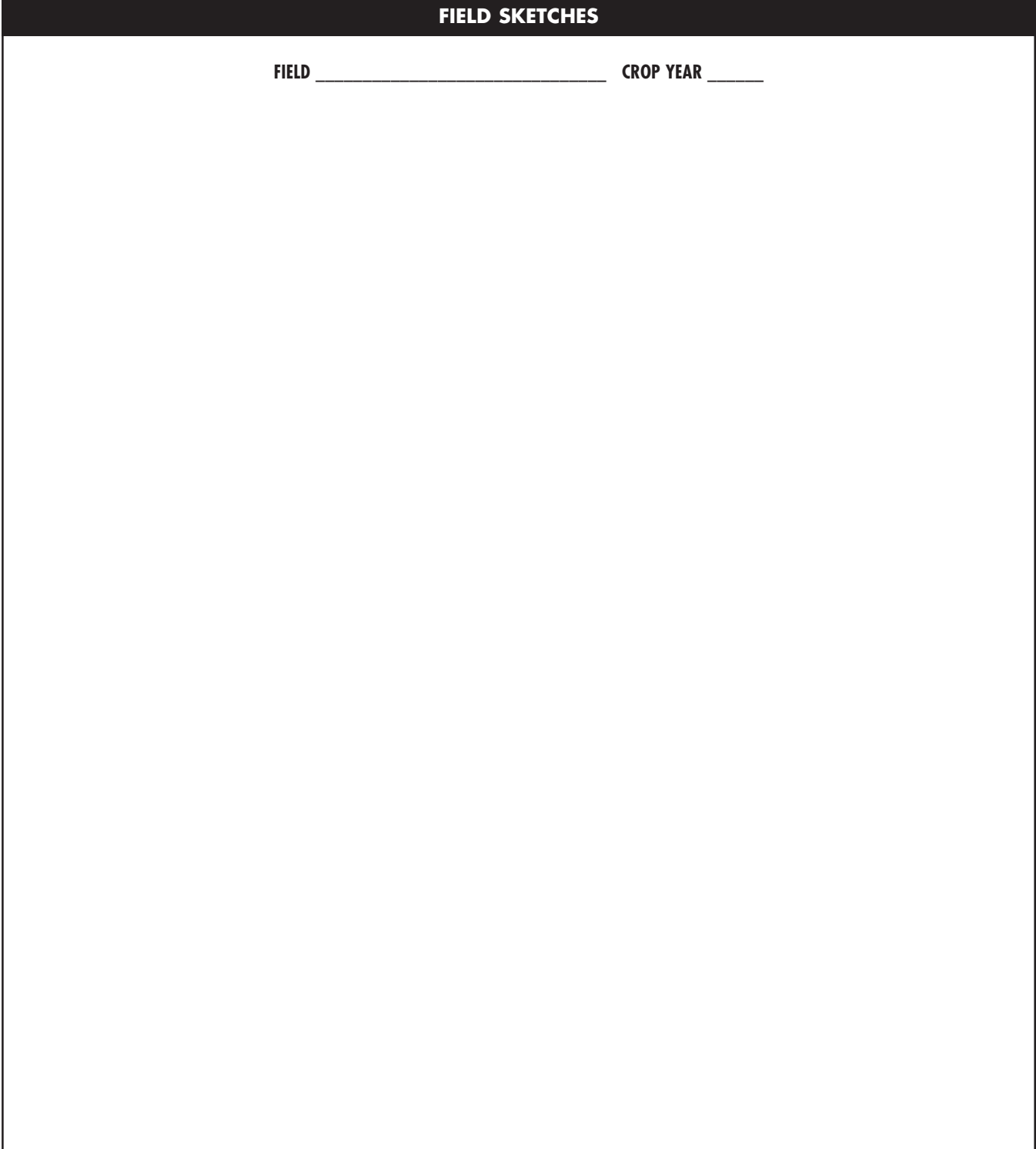



other resources

Cooperative Extension Service

You may contact the local office of the Cooperative Extension Service, located in each county.

IOWA STATE UNIVERSITY EXTENSION FIELD SPECIALISTS/ AGRICULTURAL ENGINEERS

Kris Kohl

Buena Vista County Extension
824 Flindt-Box 820
Storm Lake, IA 50588
(712) 732-5056

Greg Brenneman

Johnson County Extension
4265 Oakcrest HL SE
Iowa City, IA 52246
(319) 337-2145

Shawn Shouse

Wallace Center
53020 Hitchcock
Lewis, IA 51544
(712) 769-2600

Dan Meyer

Fayette County Extension
P.O. Box 700
Fayette, IA 52142
(319) 425-3331

Brad Woerner

Mahaska County Extension
212 . 1st Street
Oskaloosa, IA 52577-2060
(515) 673-5841

Wallace Greenlees

Dallas County Fairgrounds
Adel, IA 50003
(515)993-4281

Vacant

Winnebago County Extension
P.O. Box 47
Thompson, IA 50478
(515) 584-2261

IOWA STATE UNIVERSITY EXTENSION FIELD SPECIALISTS/

CROPS

Mark Carlton

Monroe Co. Ext. Office
107 Benton Ave. E.
Albia, IA 52531
515/932-5612
Fax: (515) 932-5662
Cell: (515) 777-7883
Email: x1mcarlt@exnet.iastate.edu

John L. Creswell

Story County Extension Office
P. O. Box 118 • 220 H Ave.
Nevada, IA 50201-0118
(515) 382-6551
Fax: (515) 382-2696
Beeper: (515) 239-2761
(leave number, hit #, hang up)
Email: x1cres@exnet.iastate.edu

George Cummins

Floyd Co. Ext. Office
615 Beck Street
Charles City, IA 50616
(515) 228-1453
Fax: (515) 228-1453
Email: x1cumns@exnet.iastate.edu

Joel DeJong

Plymouth Co. Ext. Office
24 1st Street NW
LeMars, IA 51031
(712) 546-7835
Fax: (712) 546-7837
Cell: (712) 540-1085
Email: x1dejong@exnet.iastate.edu

Jim Fawcett

Linn Co. Ext. Office
3279 - 7th Ave., Suite 140
Marion, IA 52302-3731
(319) 377-9839
Fax: (319) 377-0475
Email: x1fawcet@exnet.iastate.edu

John Holmes

Wright Co. Ext. Office

other resources

PO Box 433 210 First St. SW
Clarion, IA 50525-0433
(515) 532-3453
Fax: (515) 532-3415
Email: x1johnh@exnet.iastate.edu

James H. Jensen
Henry Co. Ext. Office
101 S. Jefferson
Mt. Pleasant, IA 52641
(319) 385-8126
Fax: (319) 385-2617
Cell: (319) 931-2203
Email: x1jjensn@exnet.iastate.edu

Paul Kassel
Clay Co. Ext. Office
110 W. 4th St., Suite 100
Spencer, IA 51301-3858
(712) 262-2264
Fax: (712) 262-8481
Cell: (712) 262-6575-2007
Email: x1kassel@exnet.iastate.edu

Brian Lang
Winneshiek Co. Ext. Office
911 S. Mill Street
Decorah, IA 52101
(319) 382-2949
Fax: (319) 382-2940
Email: x1lang@exnet.iastate.edu

Vacant
Buchanan Co. Ext. Office
1413 1st St., West-B
Independence, IA 50644
(319) 334-7161
Fax: (319) 334-6641

Carroll Olsen
ISU Extension Center
53020 Hitchcock Avenue
Lewis, IA 51544
(712) 769-2600
Fax: (712) 769-2610
Cell: (402) 660-1325
Email: x1olsenc@exnet.iastate.edu

Virgil L. Schmitt
Jackson Co. Ext. Office
201 W. Platt (Courthouse)
Maquoketa, IA 52060-2295

(319) 652-4923
Fax: (319) 652-6710
Cell: (319) 260-3721
Email: x1schmit@exnet.iastate.edu

Tony Weis
Ida County Extension Office
207 Main St.
Ida Grove, Iowa 51445
(712) 364-3003
Fax: (712) 364-3529
Email: x1tweis@exnet.iastate.edu

Michael White
Adair County Extension Office
202 S. 1st St., Suite B
Greenfield, IA 50849-9549
(515) 743-8412
Fax: (515) 743-0023
Email: x1mikew@exnet.iastate.edu

NATURAL RESOURCES CONSERVATION SERVICE

NRCS state office:

**Natural Resources Conservation
Service Federal Building**
210 Walnut Street, Suite 693
Des Moines, IA 50309-2180
(515) 284-4261

NRCS area offices:

Natural Resources Conservation Service
3539 Southern Hills Drive, Suite 3
Sioux City, IA 51106-4707
(712) 276-4648

Natural Resources Conservation Service
Federal Building
531 29th Street South
Fort Dodge, IA 50501
(515) 573-4351

Natural Resources Conservation Service
120 N. Industrial Parkway #4
West Union, IA 52175-1612
(319) 422-6201

other resources

(712) 243-1934

Natural Resources Conservation Service
507 W 7th Street • PO Box 475
Atlantic, IA 50022-0475
(712) 243-2724

Natural Resources Conservation Service
1805 W. Jefferson Avenue, Suite 2
Fairfield, IA 52556-4236
(515) 472-8411

IOWA DEPARTMENT OF NATURAL RESOURCES

Send manure management plans to:

**Iowa Department of Natural Resources
Environmental Protection Division**
Wallace State Office Building
900 East Grand Ave.
Des Moines, IA 50319-0034

IDNR Environmental Protection Division field offices

**Iowa Environmental Protection
Division Field Office**
909 W. Main, Suite 4
Manchester, IA 52057
(319) 927-2840

**Iowa Environmental Protection
Division Field Office**
2300 15th St. SW
Mason City, IA 50401
(515) 424-4073

**Iowa Environmental Protection
Division Field Office**
1900 North Grand Ave.
Spencer, IA 51301
(712) 282-4177

**Iowa Environmental Protection
Division Field Office**
706 Sunnyside Lane
Atlantic, IA 50022

**Iowa Environmental Protection
Division Field Office**
607 E. 2nd St.
Des Moines, IA 50309
(515) 281-9069

**Iowa Environmental Protection
Division Field Office**
1004 West Madison
Washington, IA 52353
(319) 653-2135

MANURE AND SOIL TESTING LABORATORIES

*Endorsement of companies is not intended,
nor is criticism implied of similar companies
not mentioned.*

Soil and manure analysis:

Dairyland Laboratories
217 E. Main
Arcadia, Wis. 54612
(608) 323-2123

Mid West Labs, Inc.
13611 B. Street
Omaha, NE 68144
(402) 334-7770

MVTL Labs, Inc.
35 West Lincolnway • P.O. Box 440
Nevada, IA 50201-0440
(515) 382-5486
Fax: (515) 382-3885

Ward Laboratories, Inc.
P.O. Box 788
Kearney, NE 68848
(308) 234-2418
www.wardlab.com

Belmond Labs, Inc.

other resources

P.O. Box 203
Belmond, IA 50421
(515) 444-3384

Mowers Soil Testing Plus, Inc.
117 E. Main Street
Toulon, IL 61483
(309) 286-2761
(800) 354-8197
Email: mowers@starkcounty.comowers

Agvise, Inc.
902 13th St. North • P.O. Box 187
Benson, MN 56215
(320) 843- 4109
Email: agvise@willmar.com
www.rrtrade.org/Agvise/index.htm

Iowa Testing Laboratory
Highway 17 North • P.O. Box 188
Eagle Grove, IA 50533
(515) 448-4741

Servi-Tech Laboratories
1602 Park West Drive • P.O. Box 169
Hastings, NE 68901
(402) 463- 3522
Fax: (402) 463-8132

L.G.I.
1532 DeWitt Street • P.O. Box 147
Ellsworth, IA 50075
(515) 836- 4444
Fax: (515) 836-4541

A & L Heartland Labs, Inc.
111 Linn St. • P.O. Box 455
Atlantic, IA 50022
(712) 243-6933
Fax: (712) 243-5213
Email: allab@nishna.net
www.al-labs.com

Soil and biosolids analysis:

Des Moines Metro, WRA
3000 Vandalia Road
Des Moines, IA 50317
(515) 323- 8001

Manure analysis:

Woodson Tenent Laboratories
3507 Delaware Ave. • Box 1492
Des Moines, IA 50313
(515) 265-1461

Analytical Services Laboratory
123 Town Engineering Building
Iowa State University
Ames, IA 50011-3232
(515) 294-8768
Fax: (515) 294-8216

Soil testing:

Harris Laboratories
624 Peach Street • P.O. Box 80837
Lincoln, NE 68051
(402) 476-2811

ISU Soil Testing Lab
G501 Agronomy Hall
Ames, IA 50011
(515) 294- 3076

Soil Management Consultants
5421 Tzrenz Court, S.W.
Cedar Rapids, IA 52404
(319) 364- 7645

Balance Labs
421 Leader Street
Marion, OH 43302
(614) 382- 5701 ext. 221

other resources
