

Conveyors for Bulk Handling of Seed

Conveyors are used to fill and unload bulk seed storage bins and to transfer seed within a seed cleaning plant. This publication describes commercial conveyors currently available. Factors for selecting the proper conveyor are presented in the concluding section.

Types of Conveyors

Auger

An auger (figure 1) is the most common device on the farm for bulk handling of seed. It is also the least expensive. The capacity of an auger depends on its speed, size, intake exposure, and angle of incline. Capacity is also influenced by seed type and moisture content. The combination of operating at less than full capacity and at high speed causes the most mechanical damage to seed in an auger operation. For recommendations to minimize seed damage caused by an auger, see Iowa State University Extension publication Pm-999 "Minimizing Mechanical Damage to Soybean Seed."



Figure 1. An auger is often used on the farm to fill bulk storage.

Auger with Rubber Intake

The main feature of this auger is a two-foot rubber intake section (figure 2). Originally a safety feature, the rubber intake offers some protection against seed damage. Hanger bearings located at fixed intervals on

the tube support the flightings, resulting in quieter operation and may reduce seed damage.

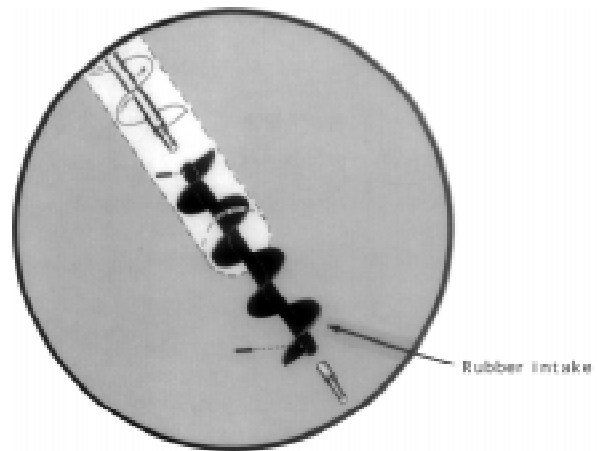

Figure 2. Auger with rubber intake.

Auger with Bristles

The bristle-auger is a recent innovation. This auger uses nylon bristles instead of metal flightings to move the seed (figure 3). Bristles at the intake are treated with silicon rubber to increase stiffness. This device may be particularly well-suited for unloading bulk seed from wagons and in conditioning plants for moving seed a short distance. Minimum seed damage occurs because of the sweeping action of the bristles. Cleaning up between varieties may be a problem with this device. Further experimentation is being conducted to alleviate this problem.

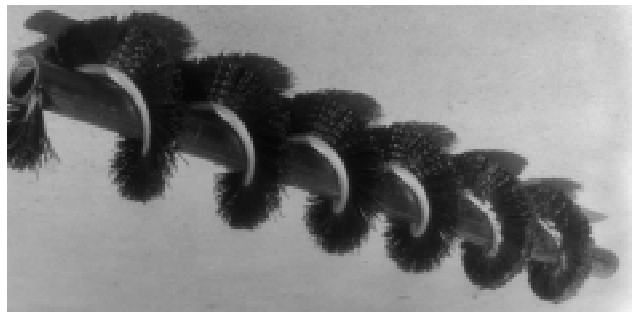

Figure 3. Nylon bristle auger.

IOWA STATE UNIVERSITY
University Extension

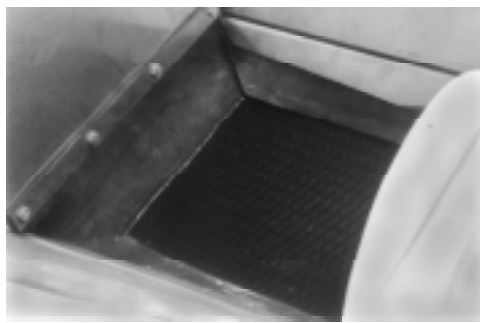

Figure 4. Belt conveyor. Inset shows the belt in the conveyor intake.



Belt Conveyor

In this conveyor, a rubber belt traveling through a steel tube carries the seed (figure 4). Since the seeds are carried on the belt, seed damage is minimal during conveying. The belt speed may also be slowed down so that seeds do not leave the end of the belt at a high speed.

A belt conveyor is often used to fill the bulk storage and to transfer seed from one piece of equipment to another in the cleaning plant. A belt conveyor also is available to transfer bulk seed from wagon to planter. The capacity of a belt conveyor depends on the speed, width, and surface characteristics of the belt. The angle of incline and the characteristics of the product being conveyed also influence capacity. Normally, a belt conveyor can handle materials at an incline up to 30°.

Flight Conveyor

The conveyor in figure 5 has rubber flights attached to a rubber belt. The flights help prevent the “roll-back” of the seed normally encountered with conventional belt conveyors. The flight conveyor can therefore be operated at higher incline angles without increasing belt speed. In another kind of flight conveyor, rubber flights are attached to a chain enclosed by a casing (figure 6). As the chain is driven forward, the rubber flights move the seed.

Inside a cleaning plant a device is sometimes used for horizontal conveying of seed (figure 7) and is referred to as a drag-flight conveyor. It is advisable to install an automatic shut-off switch in a drag-flight conveyor in case the drag chain gets plugged. Also, the inlet hopper should be placed so that seeds enter the conveyor past the sprockets to minimize seed damage. Intermediate discharges can be installed at desired locations in this type of conveyor.

Figure 5. This conveyor has rubber flights attached to a rubber belt.

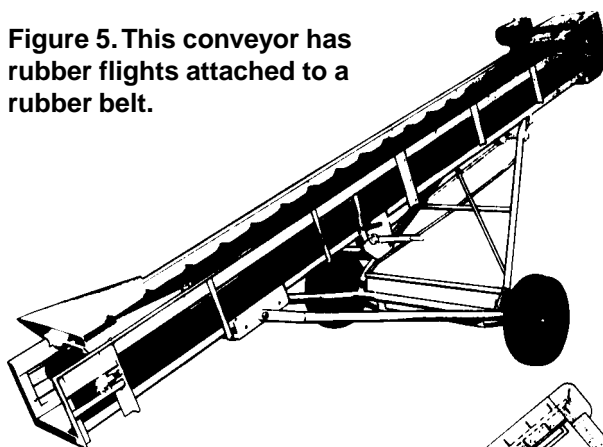

Figure 6. Rubber flights attached to a chain move the seed.

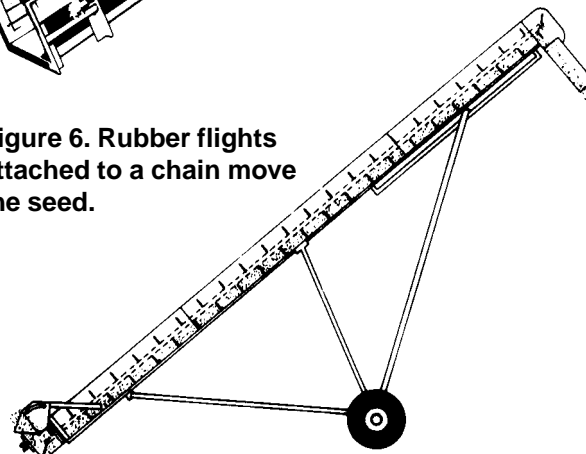

Figure 7. Drag-flight conveyor.



Bucket Elevator

A bucket elevator, as the name implies, consists of a series of buckets attached to a chain or belt and is used to move material vertically (figure 8). A properly designed bucket elevator efficiently and safely handles seed. Guidelines for selecting a bucket elevator for handling seed are covered in the publication SSC-1 "Selecting a Bucket Elevator for Handling Seed," available from the Seed Science Center, Iowa State University, Ames, Iowa 50011.

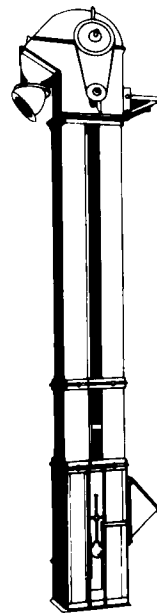

Figure 8. Bucket elevator.

Pneumatic Conveyor

Seeds in this device are conveyed by a moving airstream. Pneumatic conveyors for seed handling should be the kind in which seed by-passes the blower as shown in figure 9. The seed is conveyed through the intake pipe to the separator cyclone and into an airlock. From the airlock, the seeds drop into the discharge pipe and are conveyed to the discharge cyclone.

Figure 9. Pneumatic conveyor.

Dark arrows show flow of seed.
Dotted arrows show airflow.

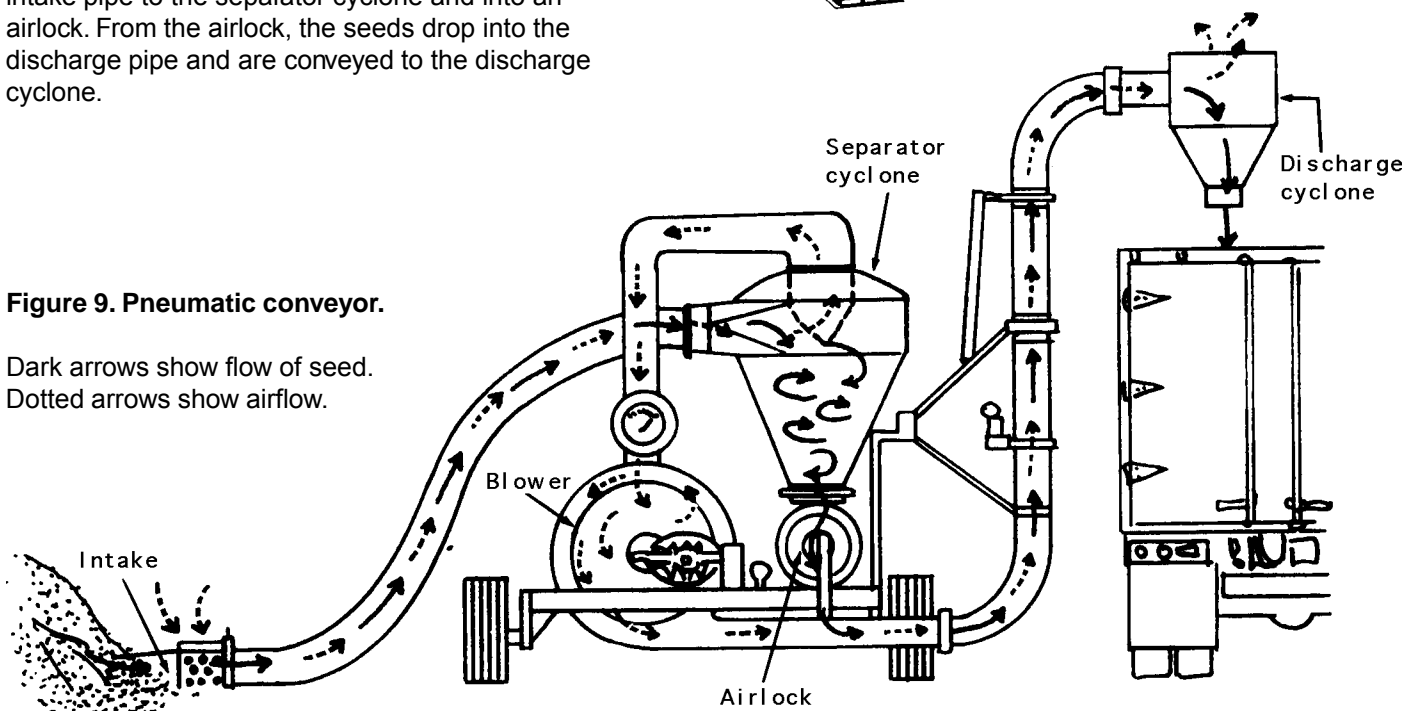

The pneumatic conveyor is versatile. It can be used for filling and emptying bulk storage and trucks. It can also be used for cleaning storage bins, spills, and places that are ordinarily difficult to clean. However, the pneumatic conveyor has higher power requirements and higher noise level than other types of conveyors.

Vibratory Conveyor

A vibratory conveyor consists of a trough supported by springs. An eccentric drive provides the vibrating action resulting in a forward movement of seeds in the trough (figure 10). These conveyors are suitable for horizontal conveying of seed inside a cleaning plant. Short vibratory feeders are often used to provide a continuous and uniform flow of materials and are suitable for blending applications.



Figure 10. This vibratory conveyor can handle two streams of material.

How to Select a Conveyor

When seed is delivered to the plant, strive to minimize conveyor-damage. For example, don't use augers unless they turn slowly and convey seeds at full capacity.

Following are some suggestions for selecting a proper conveyor for bulk handling of seed:

Damage to seed

Whenever possible, obtain the extent of damage for a particular conveyor under different operating conditions. If the data are not readily available or you want to know whether an existing conveyor should be replaced, a few trial runs will generate this information. To do this, collect samples at the inlet and at the exit end of the conveyor. The difference in seed quality (germination and mechanical damage) between the two indicates conveyor damage.

Capacity

The capacity of a conveyor will vary according to the type of material conveyed and operating conditions. Look up the capacity chart under conditions of intended use such as angle of inclination, seed type, and moisture.

Power requirement

Consider the power requirement at maximum load condition. Most conveyors can be driven by electric, gas or power take-off (PTO) equipment. Some are driven by hydraulic motors. Evaluate the advantages and disadvantages for each drive and select the most suitable one for your needs before buying the conveyor.

Ease of cleaning

Select a conveyor that is designed for easy cleaning between varieties. This will save valuable time and labor during conditioning. For example, a bucket elevator that has spacers between the belt and buckets eliminates lodging of seed and is easier to clean.

Other factors

Other factors to consider include maximum height of delivery, maneuverability, and economics.

A properly selected and operated conveyor should give years of service with minimum damage to seed. Weigh the advantages and disadvantages of each conveyor using the suggestions in this publication and install the one that best suits your needs.

. . . and justice for all

The Iowa Cooperative Extension Service's programs and policies are consistent with pertinent federal and state laws and regulations on nondiscrimination. Many materials can be made available in alternative formats for ADA clients.

Issued in furtherance of Cooperative Extension work, Acts of May 8 and June 30, 1914, in cooperation with the U.S. Department of Agriculture. Stanley R. Johnson, director, Cooperative Extension Service, Iowa State University of Science and Technology, Ames, Iowa.